



European Union  The European Regional Development Fund

The Interreg IVB North Sea Region Programme

*Investing in the future by working together
for a sustainable and competitive region*



ACCSEAS Training Needs Analysis Report

Review of the Present Situation and Approach to Training Needs Analysis

Issue: 1.0

Issue Status: Approved

Issue Date: 27/04/2015

Lead Author	Reviewer	Approved for Release
Name: Michael Baldauf	Name: Transnational Project Co-ordination Group	Name: Project Steering Committee
Job Title: Associate Professor	Job Title: Transnational Project Co-ordination Group	Job Title: Project Steering Committee
Partner: WMU, Malmö, Sweden	Partner: All	Partner: All
Signature: M. Baldauf	Signature: pp Alwyn I. Williams	Signature: pp. Alwyn I. Williams

This page is deliberately blank.

Executive Summary

This report is the final deliverable report for the research responsibilities under Work Package 4 of the ACCessibility for Shipping, Efficiency Advantages and Sustainability (ACCSEAS) research project and pertains to the Training Needs Analysis with respect to ACCSEAS candidate solutions. It is a compilation of the empirical research work undertaken for identifying the gaps in training pertaining to novel e-Navigation candidate solutions developed in the course of the ACCSEAS project.

The report features 6 chapters, each contributing to a facet of identifying the state of the art of e-Navigation training and the work with respect to engagement with training providers (instructors), end users (seafarers and pilots) and the shipping industry. Training needs analysis of ACCSEAS candidate solutions have revealed that no additional training courses are envisaged and that training for ACCSEAS candidate solutions should be incorporated within existing training regimes, for instance with Electronic Chart Display and Information System (ECDIS) courses. Training would need to include the menu items and unique features of the functionality along with intelligent filtering options to manage information and optimal use of the candidate solution. Limitations of the functionalities should be included in the training and simulation based training is considered beneficial to allow the trainees to explore the use of candidate solutions in near real life situations to comprehensively convey the potential offered by the developed candidate solutions. The report commences with an introduction to the rationale behind the study and delineates the research roles and responsibilities in Work Package 4. Chapter 2 of the report provides an overview of the research methodology and the multipronged approach followed in the study. E-Navigation training has been covered from multiple perspectives. In the first instance the view from the IMO on e-Navigation training is provided along with an overview of the courses on offer and the identification of the course content. Input from instructors is obtained with the help of semi structured qualitative research interviews to engage training providers. Further research interviews are conducted with 21 end-users (including navigators, engineer officers and pilots).

Furthermore an online questionnaire was designed and hosted to receive responses from end users which have been analysed and presented. A research workshop was also conducted to engage with participants, including those from the industry. Observations were undertaken and researchers participated in debriefing sessions of simulator studies undertaken in Flensburg, University of Applied Sciences, Flensburg, Germany and Chalmers Institute of Technology, Gothenburg, Sweden. Chapter 3 on the Training Needs Analysis, identifies the input from the diverse stakeholders and

discusses the research findings in depth. Chapter 4 provides the research output in terms of research papers and articles that have emerged and showcase the dissemination work undertaken to date. Chapter 5 provides case studies of selected ACCSEAS candidate solutions and reflectively discusses the future evolution in the provision of novel technologies including emergent technologies in the e-Navigation domain. Chapter 6 provides a sample of draft training material for a training module with integrated simulation based exercise on the use of dynamic predictions. Chapter 7 concludes the report and provides overall appropriate recommendations as identified.

Contents

1	Introduction	9
1.1	Rationale	9
1.2	Roles and Responsibilities.....	10
1.3	Terms and Acronyms	12
2	Research Methodology	13
2.1	Methodological Approach	13
2.2	Overview of research effort to engage with multiple stakeholders.....	15
2.3	The future of e-Navigation and training	15
3	Training Needs Analysis	19
3.1	Approach, Identification and extraction of recommendation/results	19
3.1.1	Training and e-Navigation strategy.....	24
3.2	View from end users – seafarers, pilots and VTS operators.....	24
3.2.1	Simulation trials at Flensburg University of Applied Sciences, Flensburg, Germany ...	27
3.2.2	Simulation trials at Chalmers, University of Technology, Gothenburg, Sweden.....	30
3.3	Questionnaire Study	33
3.3.1	Description of the questionnaire tool and key findings.....	33
3.3.2	Conclusions	36
3.4	Desk based research; courses on offer, content covered and related information.....	36
3.4.1	E-navigation courses on offer	37
3.4.2	Findings and conclusions	42
3.5	View from instruction providers – colleges and instructors.....	42
3.5.1	Aim	43
3.5.2	Method.....	43
3.5.3	Results.....	44
3.5.4	Conclusion.....	46
4	Reflection on and discussion of select e-navigation training aspects.....	49
4.1	Standardisation aspects of e-Navigation training.....	49
4.1.1	Pre-e-Navigation Education and Training	50
4.1.2	The impact of e-Navigation.....	50
4.1.3	Conclusions to improve training	51
4.2	E-navigation training issues to ensure and increase maritime safety	52
4.2.1	E-navigation – bringing together technical systems and human operators.....	53
4.2.2	Conclusion.....	54

4.3	Training aspects of ECDIS use and e-Navigation.....	54
5	Training Needs and Gap analysis for selected ACCSEAS solutions	57
5.1	General remarks	57
5.2	Tactical route suggestion and tactical route exchange	57
5.2.1	Introduction	57
5.2.2	Simulation scenarios	58
5.2.3	Training Needs and Gaps	59
5.3	NoGo Area Service	60
5.3.1	Introduction	60
5.3.2	Method.....	60
5.3.3	Operational Task Analysis (OTA)	61
5.3.4	Training Gap Analysis (TGA)	63
5.3.5	Training Option Analysis (TOA)	64
5.4	Augmented Reality and Head Up Display	65
5.4.1	Content, aims and objectives of the new service	65
5.4.2	Test concept.....	66
5.4.3	Training aspects	67
5.4.4	Suggestions for the development of a appropriate training module	67
5.5	Dynamic Predictor	68
5.5.1	Content, aims and objectives of the prototype/service	68
5.5.2	Implications for Dynamic Predictions	68
5.5.3	Simulation-based tests of the candidate solution	69
5.5.4	Simulation-test results	71
5.5.5	Comments, conclusions and outlook.....	72
5.5.6	Results and conclusions from studies into general use of dynamic predictions	73
5.5.7	Outlook.....	73
6	Draft material for sample training module ‘Dynamic Prediction’	75
6.1	Introduction	75
6.2	The need for integrated use of dynamic predictions	75
6.3	Systematic approach manoeuvring	76
6.4	Manoeuvring process and simulation-based support	77
6.5	Manoeuvring assistance using dynamic predictions	79
6.5.1	Dynamic prediction to support manoeuvre planning.....	79
6.5.2	Dynamic prediction to support manoeuvre execution.....	82

7 Conclusions and Recommendations..... 87

8 References..... 91

9 Appendices..... 93

9.1 Appendix 1: Semi structured qualitative interview tool for instructors..... 93

9.2 Appendix 2: Policies 95

9.3 Appendix 3: Guiding questions for ACCSEAS interviews with mariners 98

9.4 Appendix 4: Training provision, UK..... 100

9.5 Appendix 5: Questionnaire study online tool 101

Appendix 6: Use of Simulators in e-Navigation Training and Demonstration.
(WMU Input Paper to ACCSEAS Simulator working group) 102

Document Disclaimer

Document is uncontrolled when removed from iManage (either electronic or printed)

Document Information

Project Title	ACCSEAS
Work Package No.	4
Document Title	ACCSEAS Training Needs Analysis Report
Description	Training Needs and Gap Analysis
Date	27/04/2015
Lead Author	Michael Baldauf
Lead Author's Contact Information	World Maritime University, Citadellsvägen 29, Malmö, Sweden Email: mbf@wmu.se Tele: +46 40 35 63 90
Contributing Author(s)	Aditi Kataria (WMU) Günther Schmidt (FUAS) Mikael Hägg (CTH Gothenburg) Stephan Procee (MIWB, Terschelling)
iManage Location	29830
Circulation	1. Client 2. Project Files (i-manage) 3. Transnational Project Co-ordination Group 4. Project Steering Committee
NSRP Secretariat Approval	Yes / No

1 Introduction

This introductory chapter provides the rationale for the research study and describes World Maritime University's (WMU) roles and responsibilities in the task. WMU is responsible for work package 4 pertaining to the state of the art of training and conducting Training Needs Analysis including with reference to the services, functions and applications developed under ACCSEAS project [1]. This chapter sets the background for the report.

1.1 Rationale

The ACCSEAS project aims to identify issues which obstruct maritime access to the North Sea Region (NSR), identify potential solutions, prototype and demonstrate these successful solutions using the International Maritime Organisation's (IMO) e-Navigation concept in a test-bed in the NSR. The project has developed 'proof-of-concept' tests which will eventually lead to a proposed sustainability plan for future e-Navigation provision in the NSR and will look to inform the e-Navigation initiative globally. The entire process of the implementation of prototype solutions in the e-Navigation test-bed will be supported by training and simulation, so that the test-bed will have aspects of both, real-world and simulated implementation. The project is part funded by the European Regional Development Fund through the INTERREG IVB programme.

The ACCSEAS Project runs from April 2012 to February 2015, with a budget of over €5M. The partners are: General Lighthouse Authorities, United Kingdom; Chalmers University of Technology, Sweden; Danish Maritime Authority, Denmark; Federal Waterways & Shipping Administration, Germany; Rijkswaterstaat, Ministry for Infrastructuur and the Environment, Netherlands; Swedish Maritime Administration, Sweden; Norwegian Coastal Administration, Norway; SSPA Sweden AB, Sweden; Flensburg University of Applied Science, Germany; Maritiem Instituut Willem Barentsz, Netherlands; World Maritime University, Sweden.

Projects in the past, for e.g., 'EfficienSea' and 'Monalisa' have addressed e-Navigation while the ACCSEAS project goes further to develop an innovative test-bed of e-Navigation solutions, including resilient positioning, navigation and timing, robust e-Navigation services, safe and efficient berth-to-berth operations, dynamic route planning, information exchange, display and decision aids. The project also identifies the training required by the introduction of concept solutions in the on-board environment. The training is identified both with respect to the on-board personnel as well as the shore based counterparts like the Vessel Traffic Service (VTS).

The criteria for these decisions are based on the difficulties experienced by today's vessels navigating through the many different challenges within the NSR; but also considers those difficulties expected in the future, given the expected restriction of the seaways. The potential solutions will consider the many different services that can be provided by the many different providers as part of their e-Navigation Maritime Service Portfolio's (MSPs), which will include a review of services offered today as well as potential services that can be introduced. These new services include the potential for route guidance information, improved information exchange as well as enhanced position, navigation and timing information from multiple sources.

The implications of the proposed new services will be explained in terms of how they will benefit the mariner through the improvement in safety and efficiency.

1.2 Roles and Responsibilities

The roles and responsibilities in WP 4 are explicated by figure 1 on the following page. WMU is content wise junior partner and draws upon the input received from the other work packages in terms of the developed innovative e-Navigation candidate solutions developed as part of the ACCSEAS project and to analyse the training requirements for the services in conjunction with the responsible partners.

The introduction of new technology, equipment and solutions often requires changes in existing working schemes and processes and initiates the introduction of new procedures and new ways of working on-board and/or ashore and thus creates the need for evaluating training needs to support the crew, VTS operators, shipping companies, port operators, training providers and maritime administrators.

WMU's role and responsibility can thus be stated as the evaluation of the training needs in relation to the developed ACCSEAS candidate solutions. To do so, WMU has analysed the current training regimes and the training required to utilise the novel solutions and identified the training gaps which need to be addressed to support the implementation of the novel solutions in the on-board environment.

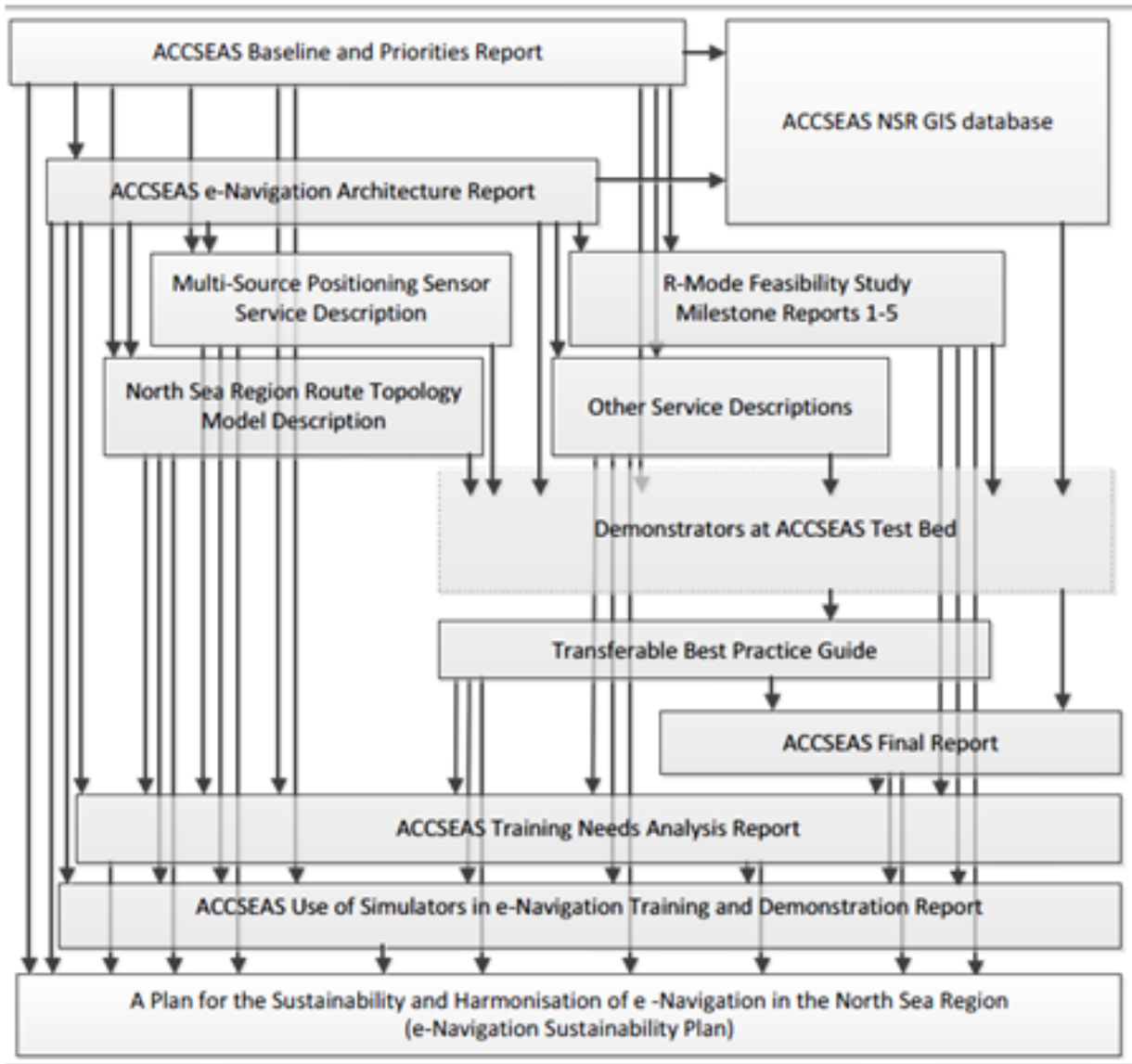

Figure 1: Suite of ACCSEAS documents and deliverables (Source: Porathe, Thomas. and Oltmann, Jan-Hendrik. *ACCSEAS Baseline and Priorities Report* [2])

1.3 Terms and Acronyms

Acronym or Term	Definition
AIS	Automatic Identification System
AR	Augmented Reality
ARPA	Automatic Radar Plotting Aid
BRM	Bridge Resource Management
BTM	Bridge Team Management
CoG	Course over Ground
CPA	Closest Point of Approach
DGPA	Differential Global Positioning System
ECDIS	Electronic Chart Display and Information System
ENC	Electronic Navigational Chart
EPD	e-Navigation Prototype Display
GMDSS	Global Maritime Distress and Safety System
HDP	Hydrodynamic Predictor
HCD	Human Centred Design
HUD	Head Up Display
IALA	International Association of Lighthouse Authorities
IBS	Integrated Bridge Systems
IHO	International Hydrographic Office
IMO	International Maritime Organization
INS	Integrated Navigation Systems
IVEF	Inter VTS Exchange Format
MET	Maritime Education and Training
MSI	Maritime Safety Information
MSP	Maritime Service Portfolio
NM	Notice to Mariners
NMEA	National Marine Electronics Association
NSR	North Sea Region
OOW	Officer of the Watch
RTM	Route Topology Model
SA	Situational Awareness
SHS	Ship-handling simulator
SIP	Strategy Implementation Plan
SOG	Speed over Ground
UCD	User Centred Design
VOCT	Vessel Operation Coordination Tool
WMU	World Maritime University

2 Research Methodology

2.1 Methodological Approach

This chapter provides the research methodology adopted for the study. WMU has adopted a multi-pronged research methodology combining desk research, online questionnaires, semi structured qualitative research interviews with diverse stakeholders and evaluations of simulation sessions to undertake a comprehensive training needs analysis for the ACCSEAS candidate solutions.

A comprehensive Training Needs Analysis (requirements, demands, existing skills and competencies) for the target groups is essential for putting effective training regimes in place for the operators.

Figure 2: From contextual work demand analysis to evaluation of training solutions



Based on the analysis, the training curriculum is required to be developed to fill the gap between existing and necessary knowledge, skills and competencies of the target group. Subsequently a tailored training can be implemented to enhance job related skills and competencies. In this way, time and resources can be saved by focusing on relevant content that is pertinent to the function of the target groups.

Figure 3: Training Needs Analysis – Key Questions and Concerns



- What are the overall aims and objectives of the new e-Navigation services or applications provided by the ACCSEAS candidate solutions?
- What are the expected outcomes of the service / application?
- Who will be the (responsible) provider of the new service or application? What is the target group?
- How the ideal functioning of procedure is defined (model case)?
- What is the potential and what are the constraints of the new solution?
- Are there training needs at the providers and at the users end?
- What are the present skills and competencies of the operators (providers and users end)?
- What are the present training schemes?
- Development of specific learning objectives
- Draft training content, structure
- Criteria to validate if training has closed the gap?
- Definition of most effective training means and media

The training gaps analysis includes a review of the state of the art of e-navigation training provision, engages with multiple stakeholders – the maritime instructors, shipboard operators and pilots and includes the analysis of simulation exercises undertaken for the purpose of evaluating the training needs of the novel e-navigation functionalities in the candidate solutions developed in the ACCSEAS project.

2.2 Overview of research effort to engage with multiple stakeholders

The methodological approach for the research includes three main actors/end users comprising mariners onboard ships (captains and navigating officers), pilots, VTS or any other shore-based service providers, and public, private organizations, institutions, service providers (limited only to training providers). A comprehensive literature review (IMO, IALA documents) was conducted first and semi structured qualitative research interviews were conducted with the stakeholders. Responses were obtained and analyzed from a questionnaire hosted online. In addition, observations of 50 simulation exercises were undertaken for the exploration of the training needs with respect to the novel e-navigation candidate solutions developed as part of the ACCSEAS project. The detailed analysis of the training needs is presented in the chapters that follow.

2.3 The future of e-Navigation and training

In the frame of the 2nd annual ACCSEAS conference, a research workshop specifically dedicated to e-Navigation subjects was held in Edinburgh in March 2014. The workshop was chaired by Associate Professor Dr. Michael Baldauf (WMU) and Mr. Anders Brødje (SMA). The chairs provided an introduction to the workshop session.

The aims and objectives of the workshop were defined as follows:

- Providing an overview of present state of e-Navigation training
- An overview of responsible institutions
- Presenting methods and ways on how e-Navigation training will be offered in the future
- To identify gaps in current e-Navigation training
- What are the best ways to provide e-Navigation training?
- How could we support approaches to training?

The present situation is mainly defined by relevant rules and regulations as well as by the model courses of IMO as well as those of IALA-AISM. Public and private training institutions currently offer different types of training measures related to e-Navigation.

In order to fuel a debate some prepared theses were put forward. One of which was that the cause of maritime accidents is not 80-90% human factor, as mentioned in several literature sources, but more due to poor equipment design including not only of the Human-Machine-Interfaces but also handling, operations of those systems as well as the operating manuals provided on-board, and this raised the question whether this was true and to what extent.

Opinions ranged from full agreement to disagreement. Agreement was supported by giving an example of having been involved in work on lifeboats. A very central issue was; where to draw the border for what is in fact human error? Does it stop at the person expected to operate a tool or solution or is there a need to further include the designer of that very same tool or solution.

Disagreement was forwarded by arguing that accidents do happen even though there is a lot of information and support available. Also organisational aspects, as e.g. required by User Centred Design/Human Centred Design (UCD/HCD) methodology recommended by IMO e-Navigation Strategy Implementation Plan (SIP), need to be included. Referring to the Costa Concordia accident, the discussion also pointed towards the organisational factors both on-board as well as ashore, with regard to the company. In order to ensure quality of training on e-Navigation in the future, there is also a need to overcome lack of availability of accident investigation reports.

The conclusion from the discussion among the participants was that it is very central for the future that any solutions or tools developed should take into account the human operators involved in the operations of those solutions or tools. There is a very strong need to refer to the actual users.

Another hypothesis discussed was; that new e-navigation-based applications support a much more thorough and comprehensive situational awareness (SA) than degrading good seamanship.

During the discussions the participants mentioned that training must include the experience and knowledge of hundreds of years which should be transferred to operators and also could be included in new equipment. E-navigation candidate solutions have the potential to make navigation easier and it might become a kind of a Play Station, but steering a ship will never become a computer game. Training must ensure a sufficient level of responsibility of the operators. However, the discussions reflected the expectation that technology will probably rather contribute to an increasing loss of SA by no longer directly observing and experiencing the environment but using displays and sensor information instead.

Alerts of e-Navigation based solutions is another highly important question that needs to be carefully and thoroughly considered to avoid false alarms leading to become overburdened by warnings and alarms. In this respect the question of type specific training was discussed and argued that even if the general idea of this is good, the comparison between aviation and shipping in this respect does not necessarily hold.

The conclusion from the discussions was that training must cover the behaviour of the mariner and how they are expected to operate on-board. The content remains the same to a large extent, but there should be no need for new types of training.

Taking into account e-Navigation candidate solutions suggested by ACCSEAS and the present situation of delivering VTS from ashore, the workshop further focussed on 'Ironies of Automation' and how negative side effects can be avoided through comprehensive training. The participants looked at different types of training and concluded that there is no single answer and a need for a case-sensitive approach is useful. Training should offer and provide a reasonable blended learning approach including simulations, on-the-job-training sessions, CBT, web-based and other methods.

Training should also try to contribute to cooperative work between operators ashore and on-board. Common training sessions can help to initiate communication and support understanding.

Overall, training for the future e-Navigation environment needs to ensure sufficient transfer of skills and knowledge from experienced to new staff. Maritime training and education will need to go along with the legal requirements but needs to be accompanied by taking into account new solutions that are driven by technological developments and their transfer and implementation in the daily business. Lifelong learning with certain kind of obligatory refresher courses can be an approach to ensure a sufficient level of quality of training for the personnel. Reduction of training needs and degrading of jobs seem to be not appropriate to approach the challenges of the future e-Navigation world.

The holistic approach to identifying training needs and providing training support is encapsulated in Table 1 on the following page.

This page is deliberately blank.

3 Training Needs Analysis

3.1 Approach, Identification and extraction of recommendation/results

Table 1: Training Needs Analysis for ACCSEAS e-Navigation Solutions (filled exemplarily and to be continuously updated)

S No.	e-Navigation Service/ functionality	Who is expected to become potential (end-) user of the solution?	What is the intended ideal operational context of the solution (purpose, aim and reference/standard operational procedure) <i>(to be reviewed by inventor/ developer/ manufacturer)</i>	What do potential end-users currently know with respect to training needs?	Present state, identified gaps between current and required training <i>(Results gained from interviews, questionnaires, observations etc.)</i>	Suggestions for training items derived from analysis performed <i>(derived from outcome of simulation trials, questionnaires, interviews)</i>
1	Tactical exchange of intended route	OOW; VTS operators; Operators in company related FOC; Pilots; other interested parties	Application on board: OOW can make use of an enhanced function integrated into an ECDIS-Display, showing the complete planned route or a section of it for all targets or single, specifically selected targets ... Application ashore: ... VTS operator can visualize intended routes of one single, selected groups or all vessels in a monitored area. (for further details refer also to WP 3 Baseline Report, WP 4 Architecture Report and Test-bed implementation Report)	Operator on board (OOW): standalone equipment (Radar, ECDIS, GMDSS, AIS etc.); IBS; INS; BRM; BTM; relevant training in accordance with the STCW [3] Operator ashore (VTS-Operator): IALA-AISM V-103 [4]	Training required with respect to functionality / solution <ul style="list-style-type: none"> Principles calculations Caveats/errors Pros and cons Familiarisation with functions Familiarisation with display and its customisation Training needs identified with simulation trials, debriefing sessions and questionnaires	<ul style="list-style-type: none"> No independent training required. Should be integrated with existing training regimes like ECDIS, Radar. Training should include menus and features of solution functionality. Training should include utilisation of intelligent filtering systems. Training should include limitations of functionality. Training should include optimal utilisation of functionality. Simulation training recommended for exploring context of use new ways of working and new communications the functionality creates. Training in standardised / harmonised use of terminology
2	Tactical Route	VTS operator and	Application on-board and	Operator on board	Training required with	<ul style="list-style-type: none"> No independent training required.

	Suggestion	OOW, pilots Operators in company related FOC; Pilots	ashore: Similar as described for solution 1, with the modification, that the VTS sends a route suggestion to avoid or solve the development of a critical traffic situation. The VTS can send a segment of the route to aid port approaches, pilot embarkation, manage congestion etc.	(OOW): standalone equipment (Radar, ECDIS, GMDSS, AIS etc.); IBS; INS; BRM; BTM Operator ashore (VTS-Operator): IALA-AISM V-103	respect to functionality / solution <ul style="list-style-type: none"> Principles calculations Caveats/errors Pros and cons Familiarisation with functions Familiarisation with display and its customisation Training needs identified with simulation trials and interviews	<ul style="list-style-type: none"> Should be integrated with existing training regimes like ECDIS, Radar. Training should include menus and features of solution functionality. Training should include utilisation of intelligent filtering systems. Training should include limitations of functionality. Training should include optimal utilisation of functionality Simulation training recommended for exploring context of use new ways of working and new communications the functionality creates. Training in standardised / harmonised use of terminology Preparation of bridge team for accepting route Training to convey that the tool does not impart any additional powers
3	No Go Area	OOW, VTS operators and Operators in company related FOC; Pilots.	Application on-board: Dynamic information related to the changing topography of the sea bed and conducive to safety depending upon the draft and the under keel clearance of the vessel Application ashore: Inform VTS service provision like INS and TOS depending upon the vessel characteristics and the state of the seabed and other hydro-meteorological conditions	Operator on board Refer to OOW training in point 1 above and navigation courses incorporating equipment like echo sounder etc. Operator ashore (VTS-Operator): IALA-AISM V-103	Training required with respect to functionality / solution <ul style="list-style-type: none"> Principles calculations Caveats/errors Pros and cons Familiarisation with functions Familiarisation with display and its customisation 	<ul style="list-style-type: none"> No independent training required. Should be integrated with existing training regimes like ECDIS, Radar. Training should include menus and features of solution functionality. Training should include utilisation of intelligent filtering systems. Training should include limitations of functionality. Training should include optimal

					Training needs identified with simulation trials and debriefing sessions	<ul style="list-style-type: none"> utilisation of functionality • Training in standardised / harmonised use of terminology <p>Simulation training recommended for exploring context of use new ways of working and new communications the functionality creates.</p>
4	Real time vessel traffic pattern analysis and warning functionality	VTS operators	Application ashore: Inform VTS service provision like INS, TOS and NAS, as appropriate depending upon the traffic and navigational situation.	Operator ashore IALA-AISM V-103	Use for operational tasks of existing and potentially enhanced VTS services needs to be defined first before training needs can be defined	<ul style="list-style-type: none"> • Integrated simulation exercises for traffic monitoring, training of warning/alert handling, meaning of warnings and required action to be taken by operators
5	Maritime Service Portfolios (MSPs) for NSR	Concerned stakeholders	not considered yet, to be further investigated	not considered yet, to be further investigated	not considered yet, to be further investigated	not considered yet, to be further investigated
6	Route Topology Model (RTM)	Policy makers Mariners	not considered yet, to be further investigated	not considered yet, to be further investigated	not considered yet, to be further investigated	not considered yet, to be further investigated
7	Maritime Cloud	Concerned stakeholders	Application: Data repository to support navigation and decision making on-board and ashore	not considered yet, to be further investigated	not considered yet, to be further investigated	not considered yet, to be further investigated
8	Maritime Safety	OOW	Application on-board and	Operator on board		

	Information/ Notice to mariners (MSI/NM)		ashore: Seamless provision and harmonised integration and display of pertinent information.	Refer to OOW training as point 1 above Operator ashore IALA-AISM V-103	not considered yet, to be further investigated	not considered yet, to be further investigated
9	Dynamic Predictor	OOW and pilots	To visualize future status of the ship as immediate response to changes of steering handles (predictions of path and motion parameter according) To plan and monitor manoeuvring sequences for the safe and efficient passage of coastal sea areas, fairways and harbour basins	While static predictions as e.g. ARPA target vectors or curved heading lines in ECDIS are known; navigators and pilots are not yet familiar with dynamic predictions and their specific underlying concepts.	End user needs to get offered familiarization with the different concepts of predictions and their visualizations. Navigators and pilots needs to become aware of the potentials and constraints of dynamic compared to static predictions.	Integrated modules (lectures, seminars) to equip with theoretical underpinnings and knowledge about the technical concept of dynamic predictors Integrated simulation exercises to demonstrate the function, the potentials and constraints. Integrated simulation exercises to become familiar with the use of a specific application of a Dynamic predictor.
10	Innovative architecture for ship-positioning comprising multi- source positioning service and R- mode	OOW and pilots		Operator on board Refer to OOW training as point 1 above	not considered yet, to be further investigated	not considered yet, to be further investigated
11	Vessel Operation Coordination Tool (VOCT)	VTS operators	not considered yet, to be further elaborated	Operator on board Refer to OOW training as point 1 above	not considered yet, to be further studied	not considered yet, to be further investigated

				Operator ashore IALA-AISM V-103		
12	Augmented reality / Head-up displays (HUDs)	OOW, pilots VTS Operators	To support situational awareness of the OOW in regard to the detection and assessment of risk of collision for encounter situations	Operator on board According to COLREG the OOW has to take into account all information available through optical sight and provided by supporting means to assess if there is a risk of collision. Navigators know COLREG and dedicated equipment (as e.g. INS/IBS, Radar/ARPA or AIS etc.)	HUDs offer another and additional source of information. Users needs to become familiar of how the system functions, what are the potentials and constraints	Lectures/seminars to equip users with the theoretical underpinnings Simulations trials (preferably in a FM SHS environment) to exercise correct use of the HUD and interpretation of displayed information. Such training might be provided by one day workshop for thorough and comprehensive familiarization
13	Automated FAL reporting	OOW, VTS operators	not considered yet, to be further elaborated	Operator on board Refer to OOW training as point 1 above Operator ashore IALA-AISM V-103	not considered yet, to be further investigated	not considered yet, to be further investigated
14	Harmonized Data Exchange – employing Inter-VTS Exchange Format (IVEF)	VTS	not considered yet, to be further elaborated	Operator ashore IALA-AISM V-103	not considered yet, to be further investigated	not considered yet, to be further investigated

3.1.1 Training and e-Navigation strategy

At the 85th Maritime Safety Committee Meeting (MSC, 2008), the e-Navigation development and implementation strategy was adopted, wherein e-Navigation was defined as –

“the harmonized collection, integration, exchange, presentation and analysis of marine information on board and ashore by electronic means to enhance berth to berth navigation and related services for safety and security at sea and protection of the marine environment” [5].

For further information related to the development of the strategy at the IMO level, please see NCSR 1/INF 5 [6]. A more recent document, NCSR 1/9 (2014) contains information on further development of e-Navigation and an implementation plan for the strategy in the annex [7].

The pertinent solutions given in the implementation plan are -

- Solution 1: Improved, harmonized and user-friendly design
- Solution 2: Means for standardized and automated reporting
- Solution 3: Improved reliability, resilience and integrity of bridge equipment and navigation information
- Solution 4: Integration and presentation of available information in graphical displays received via communications equipment
- Solution 9: Improved communication of VTS Service Portfolio

Solutions 2 and 9 in particular lend themselves to be addressed via inclusion into training for the stakeholder groups of shipboard seafarers, pilots and VTS operators with respect to the novel e-Navigation candidate solutions developed within the ACCSEAS project.

3.2 View from end users – seafarers, pilots and VTS operators

For the interviewees, it is tempting to refer to e-navigation as electronic navigation or see it in relation to ECDIS. For those interviewees who mentioned, 'integration' they were largely self-taught and not completely clear on how the concept would be practically realized on-board. The first key finding is that there is a lack of understanding of the concept of e-navigation. A total of 21 interviews were conducted, of which two were Engineers and they were not in a position to speak on e-navigation - this itself is a research finding that engineers have very limited knowledge of the concept of e-navigation and they consider it as not a part of their job. On e-navigation, one engineer said, "it's not my job."

The interviews were conducted with individuals with seafaring background, mostly from the management level. Verbatim transcription of interviews was undertaken and thereafter transcripts were coded and micro coded with the qualitative data analysis software ATLAS.ti. Data analysis has revealed several key themes in the data -

1) Training – All of the interviewees had not received any training in the concept of e-navigation. The closest e-navigation came to be mentioned was briefly as a part of BRM courses some interviewees had been a part of. Most had learned about the concept from articles in industry magazines and journals. In this aspect most were self-informed rather than having undergone any specific training pertaining to e-navigation. One interviewee had received training in Integrated Bridge Systems (IBS) but not under the umbrella of e-navigation. The interviewees believed that there should be a standard model course of the subject of e-navigation. Most interviewees have received training on stand-alone individual bridge equipment like the ARPA radar, ECDIS, GPS etc. and not on the integrated concept of e-navigation. At times the purpose and use of the functionality and its application is not very clear. For example, an interviewee spoke of three-dimensional charts in the overall monitoring system integrating three VTS sites. He said that the three-dimensional charts were, *"not for operational purposes"* and were being included for individuals who did not have a maritime background but would like to have some information about the environment of the VTS and the 3-D charts are supposed to provide the picture of the environment and the functionality was limited in its utility for maritime professionals. Interviewees expressed a desire to include simple working definitions/delimiting definitions in the training course content. One wanted that the deck officer should know the difference between a raster chart and vector chart. It was felt that the training course should focus on the capabilities of the new emerging evolving technologies. Currently this aspect is covered in a very short time. According to the interviewees the course content should be dynamic, updated and should keep pace with technology and the development of e-navigation concept. *"Yes, because this is always, there are always new things coming. So I think it should be connected to IMO, e-navigation"*. On the training course, the interviewees also expressed a desire for the course content to be proactive rather than reactive, that is before the introduction of the technology on board, the seafarers should receive training in the technology, for example AIS. With respect to the timing of such training, the desire was expressed that the training on e-navigation should be imparted to seafarers after the cadet ship and before they go on board as an officer in charge of a navigational watch. For training, the lack of harmonisation has issues for re familiarisation training when seafarers go on board different ships. It was suggested that within one company the time taken for re-familiarisation training can be minimised by adhering to procuring systems from

one equipment manufacturer. A senior Master Mariner Pilot said that in his case time was even more critical as he had to go on board and within minutes, get a hang of everything to proceed and pilot the ship safely. In which case, he heavily relied on his portable pilot unit to accomplish his task. The senior pilot felt that, at least, seafarers on-board ships have more time to familiarise themselves with their equipment.

2) E-navigation applications - interviewees mostly spoke in terms of the application of e-Navigation rather than from the point of view of training. This could be because they have not received any formal training in e-navigation and the interviewees perceive the applications of e-navigation as close to their daily work on board the ship. One respondent said that –

"If the under keel clearance is for example, is less than half of the ships draught then the alarm will be shown to the operator. The system will use the chart depth and the draught which was reported by the vessel"

Key themes pertaining to application of e-navigation are saving time, making the job easier and enhancing safety. On ECDIS one interviewee said, *"When I use paper chart, it costs too much time. For example, as I worked in a container ship, the time was very valuable"* and he believed his time was saved if he worked with ECDIS. One interviewee said that he could plan better and enhance safety in restricted waters, *"exchange the internal routes – I can make better voyage planning....yeah because bay becomes very narrow from a wide area and there are some very shallow waters"*.

3) Technology - it was felt by most seafarers that too much trust cannot be put on technology. There should be a fall-back plan. There was a trust issue with regards to the introduction of new technology. Situational awareness should never be compromised. For senior master Mariners. It was clear that they approached the new bridge systems with caution and were firm believers of traditional approaches. One senior master mariner said that to support situational awareness and encourage his bridge team to look out, he always insisted on having the door to the bridge, open, *"I always keep the bridge door open"* as the, *"bridge team should be aware of what is happening outside"*.

On the hardware and the functionalities of the technologies, it emerged that there was no harmonisation between the diverse manufacturers of equipment. However, some core basic functions remain the same. For technology, the key phrases used to describe it were, *'user-friendliness', 'ease of use', 'standard layout', 'standard functions', 'intuitive' and 'standard display'*.

4) Results - the interviews for the ACCSEAS project have revealed that there is a lack of clarity on the concept of e-Navigation, no harmonisation in training for e-navigation, there is no harmonisation in manufacturing of equipment and there is no harmonisation in operational practice for example in restricted waters there is no set harmonised CPA and some seafarers expressed concern in accepting a lesser CPA from the VTS as safety margins differ between ships and vary depending on the type of shift, cargo, sea conditions and the location, etc.

3.2.1 Simulation trials at Flensburg University of Applied Sciences, Flensburg, Germany

This section provides the analysis from the observations of the simulation trials conducted at Flensburg University of Applied Sciences, Flensburg, Germany. The simulation trials were conducted over a period of four days and primarily focused on two of the candidate solutions developed in the ACCSEAS project, namely the display of intended route functionality and tactical shore based route suggestion. Five scenarios were designed for the exercises and three bridges simultaneously took part in the exercises representing three different vessels in the scenarios. A total of 30 simulation exercises were conducted over the four days and the exercises grew in complexity ranging from the simulation of 4 vessels in the first exercise to the simulation of 22 vessels in the latter exercises which were conducted in deteriorating weather conditions. A total of 18 participants took part in the simulator study. Each bridge team comprised of three personnel of varying rank - a student of nautical science, an experienced seafarer and a licensed Master Mariner as in the case of the participating pilots. After each simulation run of a scenario, a group interview was conducted in the debriefing session that followed, which was of an average of 45 minutes in length. Group interviews in the form of debriefing sessions comprised approximately 450 minutes in total. The exercises explored the e-navigation functionalities in the developed test bed area of wind farms off East Anglia.

3.2.1.1 Seafarers' perspective

These exercises largely portrayed the view from the seafarers and several unique findings emerged including the training needs posed by the novel functionalities. This section presents an analysis of those findings. Tactical route suggestion from the shore involves electronically transferring a route segment on the ECDIS of a ship. One particular unique finding was that when the three bridge teams received shore based route suggestion, it was summarily rejected within fractions of seconds by all the bridge teams. It was subsequently revealed in the group discussion that the primary reason for the summary rejection was the lack of any reason and supporting message from the shore side when sending out the route segment. It was perceived by the bridge teams as lacking empathy and in

general lacking appreciation of their unique situation on board by the shore side and therefore the information offered by the functionality was rejected outright. This can be contrasted with the findings from the Gothenburg simulation trials in which the VTS operator prepared the bridge teams to receive the shore based route suggestion and in all instances the bridge teams complied. Therefore preparation of the bridge teams to receive the technical intended route segment from the shore side requires preparing and aligning the bridge team favourably towards the oncoming route segment and should be a part of training for VTS operators and also bridge teams to communicate the usefulness of the functionality in certain situations. The shore based route suggestion can be accompanied by VHF conversation as well as supplemented by a reason for the suggestion with options to accept it, reject it or wait to evaluate it further.

The display of intended route was considered useful in certain situations involving overtaking and crossing points etc. which could help navigators with additional information that could inform their decision-making as appropriate. The participants in the exercises commented that they checked the intended routes for vessels which were affecting their own particular route. They checked to see if the route was stable and also compared the information on the radar. For the functionality and tool to be more supportive, it was commented that more intelligent filters and colour coding would be required to support navigating officers. For instance it would be useful to acquire the target and its intended route on the radar and then hide it when no longer necessary. Another colour would be useful to indicate if a particular ship has diverted from its intended track. If a change in route brings another vessel into one's area and endangers own ship, then its route should come up again on the screen. It was seen as a tool to avoid getting into COLREGS situations and it was referred to as a '*COLREGS avoidance tool*'. The lack of familiarity with the CPD and display of intended route functionality implied that one member of the bridge team was dedicated to the particular equipment and one pilot commented that it was a planning tool for a "*well manned warship*". It was added that the bridge teams would benefit from less but more accurate information that would give them a quick overview of the direction in which the surrounding traffic is going. A very important use of the functionality was suggested in the Search and Rescue (SAR) operations in which the path and veterans can be provided by the coordinator of the operations to the different ships which will be extremely useful rather than trying to obtain the information on the VHF.

One emergent finding from the group discussions was that from the point of view of shipboard seafarers, there was a large tendency to evaluate the software and the hardware in connection with the functionality of display of intended route in particular as they were visualised as inseparable. Several suggestions were made to the IT team from DMA to improve the CPD, the functionality itself

and suggestions were made on providing intelligent filters and colours accordingly to discern relevant information; suggestions were made regarding the integration of the functionality in the ECDIS and some participants also felt regarding display that an overlay on the radar would be extremely useful.

One experienced licensed Master Mariner and pilot felt that the transmission of the route added yet another dimension to the navigation. He felt that as he was responsible for the transmitted route, he would feel obliged, pressed and compelled to follow the route in fairness to other traffic and hence would add stress to his workload.

The idea of the concept of the functionalities was considered extremely useful and if done correctly would be of great help to seafarers. It was added that the information presented should not clutter the screens and distract the watch keepers. Rather, the functionality should be as simple as possible, requiring no extra education or training sessions. Training should be integrated with existing training regimes to highlight the development of the new functionalities in particular and their optimal usage and limitations and caveats, if any to avoid over reliance and complacency. It was also discussed that it should not be required to change the route if a vessel is engaged in a temporary COLREGS manoeuvre and would subsequently get back to its original route as the general intention would remain the same.

3.2.1.2 Conclusions

Training is foreseen in the functionality itself and as it is integrated in on-board systems like the ECDIS. Training would include information and practice on how to use the functionality in the interface, navigate the interface and create waypoints and routes for transmission. The critical point with respect to training was the limitations of the functionality of display of intended route. The limitations should be included in the training and communicate that bridge teams need to keep in mind that the information displayed on their screens revealed the Closest Point of Approach (CPA) between routes and not between actual targets. The information displayed reveals the distance between vessels when they are on that particular route. Caveats and limitations of the functionality were considered essential with respect to training to avoid overreliance. Training in intelligent filtering to avoid cluttering the screens was also considered essential by the seafarers. With respect to training, it was further added that there should be a Computer Based Training (CBT) from the manufacturer providing training on the integration of the functionality, its use and limitations. CBT should be further complemented by in-house training regimes of companies and should be integrated into training courses like that on ECDIS, which would do away with the need for any

additional training. Simulation training to immerse the trainees in scenarios which highlight the value of the information and support provided by the new candidate solutions, would add further value to the training programme.

3.2.2 Simulation trials at Chalmers, University of Technology, Gothenburg, Sweden

This section addresses ACCSEAS candidate solutions of *display of intended route* and *shore based route suggestion* in a simulation environment. This section presents the findings of the simulation trials conducted at Chalmers, University of technology, Gothenburg Sweden. In all, a total of 5 scenarios were designed for the simulation trials. The 5 scenarios were covered in 2 days and in total 10 exercises were conducted over the 4 day period. Two bridges participated simultaneously in the exercises leading to data generation from 20 simulation exercises. The bridges were manned by two professional seafarers with experience as a Master or a pilot. A unique nature of the simulation scenarios was that VTS were integrated in the exercises and this enabled the perspective of the training needs from the shore side to be explored. Personnel from the river Humber in England were present which included a VTS operator, Harbourmaster and a pilot. The realistic scenarios developed for the trials included approaches to Humber, congestion at Immingham and Grimsby. Rerouting was considered for vessel leaving deep water anchorage to be well clear of buoy, rerouting was also considered in the outer traffic separation scheme during rough weather. The novel e-navigation candidate solutions being explored pertained to display of intended route and shore based route suggestion.

3.2.2.1 VTS' perspective

From the VTS' perspective, it was extremely helpful to see the intended routes of vessels displayed on their screens. It was useful for the VTS to see the planning and the intention of the vessels in the area as this would enable them to proactively resolve any safety concerns in a timely manner. Shore based route suggestion was considered extremely important from the perspective of the VTS as this enabled them to undertake the work they were already doing but in a more efficient manner, especially since it can be sent electronically and the vessel would have a more concrete idea by receiving the route rather than taking down notes from VHF interactions. Operational safety can guide the alternate route suggestion based on congestion and the traffic situation, non-availability of berth or pilot etc. Avoiding delays and managing the seamless movement of marine traffic can also be undertaken by shore based route suggestion which is further based on the display of intended route functionality by the vessels.

The unique nuances of a harbour/port guide the use of shore based route suggestion functionality at particular geographical locations or stages of a vessels journey in the harbour. Giving the example of Humber, it was highlighted that prior to the establishment of the traffic separation schemes, ships would converge to Humber from all directions like *“bees to a honeypot”* and while departing would scatter in all directions like a *“starburst”*. The establishment of traffic separation schemes brought order to the harbour. However, weather and traffic conditions might dictate the suggestion of alternate routes to approach Humber. An example was given in which the ship was unable to make the appropriate entrance into the traffic separation scheme and the strong tide pushed the ship onto the buoy and the ship got into *“quite a state”* with its propeller entangled. Seeing the transmitted route of the ship, the VTS operator can judge if the ship has planned sufficient space to manoeuvre into the traffic separation scheme which would avoid the accident described above. *“A picture is worth a thousand words”*, he added and particularly for Humber approaches and exits, it would be extremely useful.

A unique benefit of the simulation trials was the opportunity to observe real VTS operators negotiate with on-board bridge teams on VHF and prepare them for receiving the suggested route. These operational procedures of preparing the bridge team on the VHF, emerged as a unique finding and this procedure would need to be incorporated in the training of VTS operators. ACCSEAS simulation trials in Flensburg, Germany had revealed the distrust of the bridge team to the received route; when it appeared on the screen without an accompanying message or reason for the alternate route suggestion, in which case the bridge team would reject the route within seconds of receiving it, while in the case of prior preparation of the bridge team, the route was accepted by the ships and incorporated in their navigation and manoeuvring plans. The preparation of the bridge by the VTS operator to receive the route suggestion, helps to align the bridge with the VTS' perspective as the VTS operator said that the ships would be very defensive if the shore were going to send a route suggestion out of the blue, which would also be inappropriate. From the VTS' perspective, it was crucial to receive positive confirmation that the route that they have sent has been received on board.

The VTS operator was not of the perspective that the new functionalities altered their work dramatically/fundamentally as in a sense they would continue to do the same job, however with improved efficiency. On the one hand he mentioned that there could be additional workload, however but the reward and the payoff is that they would be able to *“get it right the first time”*. On the other hand, work load would reduce by not having to repeat themselves on the VHF trying to get the message across to the ships. In such cases it would lead to the reduction of the work load by

doing away with redundant repetition. Another benefit of sending the shore based route suggestion, according to the VTS operator is that the graphical format of the picture is more useful to convey the new route as the picture communicates more emphatically and tells a story. Another safety fall out according to the VTS operator is that the VHF would not be blocked unnecessarily and would be left free for crucial safety related communication.

A key concern from the perspective of the VTS was the responsibility/liability for the e-navigation functionality of shore based route suggestion. The VTS operator added that the terminology states *“suggested route, doesn’t say it is a compulsory route”*. Prior to the utilisation of such functionalities safety standards should be put in place and the message sent across to all and training should be given. The terminology used should fit the legal side of the particular harbour/port, then that would be acceptable. The VTS operator added that *“you’re telling a ship where to go. You’re doing that now... but now you give a picture and they can put the two together”*. Training for VTS operators should include training in the functionality itself, training in procedures to support utilisation of functionality and to communicate to the VTS operators that it is an additional tool to enable the VTS operators to do their job more efficiently and to impress upon them that it does not give them any additional powers. Further, with respect to training, the perspective of the VTS operator was that simulation training with scenarios was relevant to them as a port authority as it is a hands-on tool and seminars and computer-based training would not cut it for them. It is a supplement and not a substitute. From the perspective of the VTS, the route is a part of the ships passage plan. The ship has to check the suggested route and once it takes ownership of it, in effect the ship accepts it and is thereafter responsible for it. From a technical point of view it would be useful for the new suggested route to merge successfully with the old route and change colour to indicate that it has been accepted by the ship.

The VTS operator participating in the simulation trials added that he visualises such a function incorporated in the VTS in the future. He said *“Absolutely. We want it. We are going to miss it when we go home”*. The VTS operator’s team would like to ask ships, *“Where is your route?”* He added that if the e-navigation functionalities of display of intended route and shore based route suggestion have been identified as useful, then they should be considered useful for all ships and not just for a few. It was stated that the port cannot bar entry to a particular vessel if it does not have the necessary equipment and will not force a ship to procure a new piece of equipment. There could be imbalanced development as the shore can have all the equipment but if the vessels are not transmitting, then it would not be of any use. To prevent imbalanced development, test beds of areas where everyone will be required to have this equipment should be established and thereafter slowly expand to other

geographical regions would be the way to proceed as suggested by the VTS operator. In relation to the VTS operations, it was stated that at times 40% of the vessels could declare particulars of the voyage wrong and it would be extremely important and useful to see vessel routes for any potential conflict.

3.2.2.2 Conclusions

The novel e-navigation functionalities of display of intended route and shore based route suggestion were considered extremely useful by the VTS operators. With respect to the training needs, particularly to the needs of the VTS, the following can be concluded - the legal aspect of the functionality should be watertight and included in the training of the VTS operators. The VTS operator should get training on the equipment itself and the use of the functionality, in the limitations of the functionality, the VTS operators should be trained in procedures to incorporate the functionality in the daily work, including the preparation of the bridge team to receive the shore based route suggestion, the VTS operator training should include messages on considering the functionality as a supplement/additional tool to help them perform their work efficiently without giving them any additional powers. Finally it was noted that the training would be most effective if scenario-based simulation training was carried out by the VTS operators to make it relevant to their working lives.

3.3 Questionnaire Study

This section presents the results of the questionnaire study with particular emphasis on training needs related to e-navigation.

3.3.1 Description of the questionnaire tool and key findings

A questionnaire was developed and disseminated (see appendix) to receive further seafarer input and support the interviews and simulation exercises being undertaken as part of the ACCSEAS project. The questionnaire covered the background of the participants, their training thus far, their knowledge of e-navigation and its applications and any courses they have undertaken especially respect to e-navigation. The tool was further developed for the simulation exercises being conducted as part of the project to garner input particularly with respect to the functionalities being explored in the simulation exercises.

A total of 14 seafarers took part in the study, of which 13 were male and one female. One respondent was from South America, while 13 respondents were from Europe. The respondents varied in rank from a deck cadet through to the captain. 6 of the 14 respondents were Captains, 1 First Officer, 2 Second Officer, 1 Third Officer, 3 Cadets and one respondent did not declare. The respondents had a wide experience of serving on board diverse ship types like Ro-Ro cargo/carriers, container vessels, general cargo vessels, gas and chemical tankers etc. The pilots served on-board diverse ship types due to the nature of their job.

The seafarers had undertaken training in nautical science, maritime transport, logistics etc. in their home countries required to fulfil the requirements for the award of the relevant certificate of competency. Training also included on board study in relation to theoretical study. Most of the respondents had received internal training in the form of short courses organised by the company which included chemical tanker courses, Electronic Chart Display Information System (ECDIS) including type specific, ship handling, Bridge Resource Management (BRM), Bridge Team Management (BTM), RoRo, passenger ship, lifesaving equipment, cargo programs, Hazardous Material course (HAZMAT) etc. Most participants were satisfied with the training they had received except one who stated he was dissatisfied. The respondents pointed out that there was good infrastructure in Europe and sufficient possibilities for good quality training and the training was in accordance with the IMO rules.

10 participants indicated that they were aware of the concept of e-navigation and they had mostly learnt about it through books, colleagues, University and other sources which included attending the previous ACCSEAS conference for one respondent. The participants defined e-navigation in their own words and presented below is a selection of the respondents' definitions of e-navigation.

- Enhanced Navigation is the possibility for the mariner to gather additional nautical information from shore side that is automatically integrated in the ECDIS.
- Combine all the technical information to get a better overview and safer traffic on sea
- Connecting all information to get a bigger picture of the traffic situation which is enriched by all data possible and especially necessary to have. And by this giving more safety to the navigation.
- E-Navigation increases the safety of navigation by exchanging and communicating data between ship to ship as well as ship to shore (more Information, less workload on the bridge)

The applications of e-navigation in the work of the respondents were explored and the respondents provided their input. For a pilot, building up of an information system which could help to assist ships would be a useful application of e-navigation solutions. ECDIS was identified as a useful platform to receive up to date information about ship movements, eta etc. in an easy manner. The seafarers sought information from different avenues like the radar, ECDIS, DGPS, ARPA, AIS, weather routing etc. A respondent noted that e-navigation integrated solutions, *“there should be better user-friendliness and presentation of data without compromising data volume”*. Potential applications of e-navigation in the work of the respondents were – ECDIS in the cabin of one officer as a bridge application; obtaining integrated weather, tide and traffic information, additional layer based website with data which can be uploaded/downloaded to a ship’s e-navigation station with the option to include or disable layers. One respondent required up-to-date berth information for all ships, another wanted a traffic overview and to see planned routes. The easy availability of information was considered important. Presentation of relevant information on one or two screens was considered useful to prevent information overload and filtering was considered essential to customise information display. Ship to shore communication via ECDIS would be further adopted according to one respondent and recommended tracks could be sent to ships directly in the ECDIS along with other important information like weather routing and to achieve fuel efficiency etc.

Seafarers provided their opinions regarding un-integrated equipment and systems and said on the one hand there are advantages for replacing and maintaining independent equipment but attention can be diverted to each and every equipment which increases the work load and decreases attention that can be paid to traffic at sea. One respondent felt that the radar should be integrated in the ECDIS display with a bigger size and higher resolution. A respondent found it useful to find all information in one system in a predictable manner. A flip side of integration was also identified as it could lead to information overload and additional workload and could lead to too many alarms which can be distracting while sailing in difficult waters as each and every alarm has to be checked and acknowledged.

Re-familiarisation training on-board different ships fitted with equipment from different manufacturers was considered useful by respondents, who felt that there should be additional courses to familiarise crew with navigational equipment. It was also noted that such training should be simple and basic and should include differences from other systems to avoid redundancy.

The respondents identified different information they would like to acquire from other parties like the VTS or pilots. From pilot stations, ship officers would like to know pilot embarking positions,

means of embarkation and exact pilot boarding time. A pilot stated he would like to know the course, speed and size of the vessel. Pilotage information was considered useful to receive. Ships would like to know the number of vessels and the kind of traffic in the area, the best route and if any restrictions are in place. One respondent felt that it would be useful to know the position of other ships, berth availability, weather information and tidal information, AIS information etc. Information regarding special circumstances in the area like dredging or other works that could impair navigation etc. should be provided. Participants would like to share information with other entities like the VTS and other ships in the vicinity. They would like to share information about visibility, manoeuvring, intentions, weather, traffic planning, AIS routes, dangerous goods data and all information required by the different reporting system. Respondents also wanted to share the destination, berth and draft etc. One respondent also felt that it would be useful to share information when the vessel cannot navigate as required or when it needs special attention by other vessels for any reason.

3.3.2 Conclusions

The seafarers had undergone training in standalone systems including type-specific equipment, however they have essentially not undertaken any training with respect to e-navigation in particular. It was noted that training should be provided a good understanding of the concept with its advantages and limitations of the candidate solutions in a manner so that there would be no additional workload. The training should be simple and not too theoretical and should also be performed on board. Possibilities of e-navigation should be demonstrated to the trainees. One respondent felt that e- navigation should not have any specific course as it is a concept upon which solutions and enhancements can be further developed so training courses should be made to include a variety of new developments once they have been completed and introduced. Separate training for the concept might add to the frustration and confusion for the Mariners.

3.4 Desk based research; courses on offer, content covered and related information

This chapter presents a review of the state-of-the-art of training provision with respect to e-navigation. A comprehensive training needs analysis requires an analytic review of the latest state-of-the-art of e-navigation courses on offer, the course content, course duration, end users of the courses and related pertinent course information.

In line with the objectives of the chapter, desk-based research was undertaken to explore and identify the prevalent diverse training regimes pertaining to e-navigation. The review of e-navigation training provision includes training regimes across different countries. Extensive search queries were

conducted for identifying training courses on e-navigation utilising different query words – ‘course’ and/or training in combination with ‘e-Navigation’, ‘e navigation’ and ‘e-navigation’/ ‘E-navigation’. Different phraseology/terminology was utilised in the search queries to maximise generation of results.

What follows in this chapter is the enumeration of the findings. The first and foremost finding is that there is no model training course on e-navigation for the key stakeholders of e-navigation strategy - shipboard seafarers and shore based VTS operators. The only available model course on e-navigation has been put forward by IALA-AISM and the course is titled, ‘L1.4 Introduction to e-navigation’. Noteworthy is that this course is not for a stakeholder group which will be performing e-navigation application related duties/services, but is for managers and, as of today this course is not being offered by any training institute/organisation.

3.4.1 E-navigation courses on offer

The authors acknowledge and highlight that e-Navigation is not synonymous with electronic navigation. However a trend is discernible in training provision wherein there are a number of training courses on offer which utilise ‘e-Navigation’ as a promotional tag and provide training under this umbrella term. The following section provides an overview of the landscape of the courses on offer under the term of e-navigation.

3.4.1.1 IMO Model Courses

The review of e-navigation training provision begins with a review of the IMO model courses. The IMO is a specialised agency of the United Nations organisation specifically addressing Maritime safety, security and protection of the marine environment. The organisation addresses training needs of seafarers via the STCW (1974, as amended) (Standards of Training Certification and Watch Keeping) convention.

The IMO has no model training courses specifically pertaining to e-navigation for seafarers. The IMO model courses address operation of individual stand-alone equipment like radar (IMO model course 1.07), AIS (IMO model course 1.34), ECDIS (IMO model course 1.27) etc. The courses that come close to/or are related to e-navigation are –

- 1.32 IMO Model Course: Operation Use of Integrated Bridge Systems
- 1.27 IMO Model Course: Operation use of ECDIS
- 1.22 IMO Model Course: Ship Simulator and Bridge Team Work

IMO has propounded the e-navigation strategy for consideration in the Maritime domain, however the IMO has no training in place related to e-navigation for seafarers. IMO only caters to seafarers as end-users and other stakeholders in the e-navigation strategy like the VTS operators are not addressed by the IMO but by IALA-AISM.

3.4.1.2 IALA-AISM Model Courses

International Association of Lighthouse Authorities (IALA) is a non-profit organisation that is primarily concerned with training and capacity building, particularly for the VTS operators, who are a key shore based stakeholder in the e-navigation strategy.

The only model course pertaining to e-navigation is the one put forth by IALA-AISM. The course is an introduction to e-navigation and as of now is not being provided by any training provider. For the full course details, see appendix.

- L1.4 Introduction to e-navigation
 - Duration – 6 hours/1 day
 - Modules – 5
 - Module 1 – The background to e-navigation; inception, adoption and development of concept
 - Module 2 – Electronic nautical charts and ECDIS; importance of valid electronic chart data to support e-navigation
 - Module 3 – Position navigation and timing; uninterrupted determination of position, navigation and coordinated time is essential to the navigation
 - Module 4 – Communications and AIS; communication systems necessary to support e-navigation
 - Module 5 – information systems; existing and developing information systems designed to improve the flow of information between ship to shore, ship to ship and shore to ship

This course is for aids to navigation managers to introduce the concept of e-navigation to this group. This course is not for frontline providers of navigation services who are the VTS operators.

IALA has courses for training of VTS operators but none specifically on the e-navigation concept. A selection of courses that specifically pertain to the training and certification of VTS operators and supervisors are –

- V-103 On standards for training and certification of VTS personnel 12/2009
- V-103/1 Model Course - VTS operators basic training 12/2009
- V-103/2 Model Course - VTS supervisors - Advancement training 12/2009
- V-103/3 Model Course - VTS on the job training (VTS operator and VTS supervisor) 12/2009
- V-103/4 Model Course - VTS on the job training instructor 12/2009

Another e-Navigation Model Course that has been found during the survey is one that has been developed in the frame of an IAMU funded research and development project under the leadership of California Maritime Academy together with partner Anacapa Sciences Inc. in 2011 and 2012.

3.4.1.3 USCG Approved Courses

The review of training regimes pertaining to e-navigation include courses offered in different countries including the United States of America (USA). In the US, the United States Coast Guard (USCG) is the responsible government organisation addressing maritime training requirements.

The USCG lists courses on Bridge Resource Management (BRM) and ECDIS and electronic navigation. The search revealed that the USCG lists and approves a limited number of courses titled electronic navigation, which is in addition to the ECDIS courses on offer. To peruse the USCG courses, visit the link below:

<http://www.uscg.mil/nmc/courses/default.asp?tab=1>

A review of select Electronic Navigation courses approved by USCG, follows.

a) Course name – Electronic Navigation – OICNW

Duration – 40 hours

End user – Officer in Charge of a Navigational Watch

Content – covers theory and practical use of electronic navigational aids. Possible errors and limitations are identified including methods for resolving position ambiguity. Content includes basic

principles, GPS, echo sounders, speed logs, Loran C, radio direction finders, radar navigation, ECDIS, navigation software

Course provider – <http://www.mptusa.com/our-courses.cfm>

b) Course name – Electronic Navigation

Duration – 40 hours

End user – Officer in Charge of a Navigational Watch

Course objectives – ability to use ECDIS for navigational watch, operate ECDIS equipment, use its navigational functions, select and assess relevant information and take appropriate action. Possess knowledge of electronic charts and legal aspects related to use of ECDIS. Further objectives include the planning and conduct of passage and determining position. The course is designed to meet the requirements of electronic navigation. The course provides basic theory and use of ECDIS and understand its potential as aid to navigation and increased situational awareness in real navigational environment

Course provider – http://mamatrains.com/home/view_course_with_catogory/310

c) Course name – Voyage Planning and Electronic Navigation (VPEN)

Duration – 35hours (5 days)

End user – Officer in Charge of a Navigational Watch (experience in Maritime navigation)

Course objectives – to provide knowledge, understanding and proficiency in appraising and planning a voyage and using bridge electronics like GPS, gyro compass and autopilot in the voyage plan. Practical knowledge emphasised in magnetic and gyro compasses, Mercator and great circle sailings, GPS, stewarding and control systems, integrated bridge systems, voyage planning and navigation.

Course provider – http://www.qualitymaritime.info/CourseList_3.html#VPEN

d) Course name – Voyage Planning and Electronic Navigation (CMM-VPEN)

Duration – 5 days

End user – 3rd and/or 2nd Mate upgrading to Chief Mate/Master

Course content – great circle and Mercator sailing, tidal calculations, ocean routing, voyage planning, GPS, DGPS, magnetic compass, gyro compass, adaptive autopilots and integrated bridge systems.

Course provider –

http://mitags-pmi.org/courses/Voyage_Planning_ampersand_Electronic_Navigation

3.4.1.4 E-navigation training provision in other countries

The review of e-Navigation training provision involved review of training regimes in other countries like the United Kingdom (UK) and a developing country such as India. The UK has no course pertaining to e-Navigation but has an approved list of providers for the ECDIS course (see list on page 6). For MCA courses visit the link below:

<https://www.gov.uk/mca-approved-training-providers-atp>

UK, MCA approved ECDIS courses range from 1 day to 5 days –

- ECDIS generic training – 40 hours (4-5 days)
- ECDIS type specific training – 8 hours
- ECDIS on-board familiarisation – 1 day
- ECDIS management – 16 hours (2 days)

Courses on Bridge Team Management (BTM) and Bridge Resource Management (BRM) are provided by private training providers in the UK, however the courses are not approved by the MCA.

In India, the Directorate General of Shipping, under the Ministry of Shipping addresses seafarers' training and certification. DG, Shipping, India approves ECDIS courses but private training providers also provide Bridge Team Management and Bridge Resource Management Training as required.

In India, a private training provide like the Anglo Eastern Training Academy, provides DG, Shipping approved ECDIS courses where it is conveyed that the ECDIS is the focal point of the Integrated Navigation System. An overview of one such course is provided below.

a) Course name – ECDIS

Duration – 5 days

End user – Masters, Deck Officers, Deck Cadets and Pilots

Course content –

- Legal requirement for the carriage of ECDIS and backup systems
- Structure of ECDIS and ENC
- Performance standards for ECDIS (IMO Resolution 817 (19) including revised performance standards for ECDIS, MSC 232 (82) adopted on 5/12/2006
- Revision of SOLAS Chapter V

- Setting of ECDIS and back-up ECDIS
- Principle type of electronic charts – vectorised, raster, S57 vectorised
- Formats used for the database S57/S52
- Descriptions of the projections used for ENC
- ECDIS as the focal component of an Integrated Navigation System
- Raster charts – limitations and comparisons
- Updating ENC methods – automatic loading, semi-automatic and manual corrections
- Possible errors in displayed data
- Input sensors to ECDIS
- Radar and ARPA interface and overlay
- AIS targets display and information
- Passage planning and logbook function
- SAR operation
- Additional database information such as tidal streams, true wind and weather overlay
- Recording and playback of voyages performed on ECDIS
- Dangers of over reliance on electronic systems

Course provider – Anglo Eastern Maritime Training Centre: <http://www.maritimetraining.in/all-courses.htm>

3.4.2 Findings and conclusions

There is no model training course on e-navigation for seafarers or VTS operators. There is no course either from the IMO or from IALA-AISM for e-navigation end users. The only model course on e-navigation is an e-navigation concept introduction for Aids to Navigation Managers. The United States has courses titled Electronic Navigation which have been reviewed in section 1.1.3. Some of these courses are taught in conjunction with vessel voyage planning. The USCG also has courses for ECDIS and BRM. In other countries such as the UK and India, ECDIS is approved by the relevant government organisation while private training providers impart training on BTM and BRM as per demand. If harmonisation is a driver for the e-navigation strategy then training for the shipboard and shore based end users needs to be addressed urgently.

3.5 View from instruction providers – colleges and instructors

The ACCSEAS project of the INTERREG IVB North Sea Programme (NSP) intends to make an implementation of a North Sea e-Navigation test-bed. In advance it is a crucial work to be given a description of potential gaps between present day e-Navigation services, training and to identify

present day needs at North Sea Region (NSR) Maritime Academies. The development of the new or changed technologies is on-going. The education and training of e-Navigation needs to incorporate these changes continuously. New technologies also give other possibilities for services, on the other hand it can give more complex educational and training conditions. The teachers in e-Navigation at Maritime Academies, as respondents, is an important group because of their crucial positions and role in the complex subject of e-Navigation.

ACCSEAS is a trans-national project that brings together countries around NSR such as Denmark, Germany, the Netherlands, Norway, Sweden and the United Kingdom. The trans-national co-operation between the partners in this task and the interpretation of the results are needed, to achieve the objectives for NSR.

3.5.1 Aim

The aim of this task is to give an insight, a description of potential gaps and needs between e-Navigation services vs. education and training at six North Sea Region (NSR) Maritime Academies, one in each country that is involved in the project.

3.5.2 Method

A semi-structured interview (Appendix 1) was developed together with participants in WP3. Literature-studies about e-Navigation, documents from IMO, IALA and IHO were considered and discussed. (WP3-participants added some questions external to the aim, which are not included in results and conclusions)

Respondents at different maritime academies were suggested by the participants in the task. None of the academies or educational facilities is involved in the ACCSEAS-project. The academies were contacted and the respondent, a teacher involved in the training of e-Navigation, was selected according to their availability. An interview was scheduled either by phone or a Skype-meeting.

In advance of the interview a leaflet concerning the ACCSEAS-project was sent by mail to the respondents. None of the questions were sent in advance to the respondents despite their suggestions to do so.

At the appropriate moment, the respondent was called and given information about the approach comprising a semi-structured interview. The participant was assured of anonymity and informed that the interview would be transcribed and were further informed of the possibility of reviewing the

transcribed text should they choose to do so. The opportunity to ask questions was given before commencing the interview but also afterwards. These opportunities were used by the respondents.

3.5.3 Results

All six respondents were Master Mariners and had longer or shorter experiences of the profession at Sea in different positions and in different companies before entering the teaching arena. The sample includes a range of respondents from professor to lecturers with 3-23 years of navigational training and gradually more and more exposure to electronic navigation. All of them have taught in electronic navigation, in some way; the most common seems to be the chart-system ECDIS, according to their comments. Membership in committees regarding e-Navigation in the future was also mentioned by the respondents.

The academies of electronic navigation range from universities to private training centres. All have an extended experience of students and seafarer training in the subject of navigation. Gradually, there has been an increase in the amount of electronic equipment. The supply of money has a major influence on the amount of equipment as well as the lack of policies regarding hardware and software. Model-courses are considered positive but the development is so fast that these guidelines are soon outdated with respect to the training and the purchase of new equipment. Discussions occur between teachers about training but no simulator cooperation exists. In one case a teacher did not want to send course plans due to a previous experiences of abuse. All suggested an urgent call for earlier guide-lines in the direction of e-Navigation and provision of on-going feed-back from authorities. Their suggestions concerned updated information on hardware, software and training.

A call for a common definition of e-Navigation is apparent. To be able to answer questions regarding e-navigation you need to understand what is included. The teachers' answers also show a discrepancy about the content; from being very informed to being more limited and hardware-oriented, despite the call for a common definition. During the interview the respondents were interested in getting a definition by the interviewer to be able to "give the right answer".

Electronic navigation is already included in different parts of the subject of navigation. One of the academies had a different structure; four courses, where the last three were about electronic navigation. Number 2 was about e-Navigation in general, number 3 was about planning, operation, VTS-system, communication ashore and meteorology and number 4 was about management. It was

a mix of theoretical studies, lab-work, simulator training and bridge. No special pedagogical method was used by this academy.

A common content was the chart-system of ECDIS, which was more or less integrated with other equipment. Nevertheless, paper was still used to “send new directives and urgent messages” when using the simulators. The differences in integration were hence obvious and training was established after the circumstances. The teachers, in some way according to their comments, defended the lack of an integrated fully equipped simulator with the differences amongst vessels with ECDIS, TRANSAS or KONGSBERG and radar. Reporting and communication were not mentioned to the same extent.

Appendix shows, a table of gaps and needs mentioned during the interview. Key areas of gaps in e-Navigation are policies, equipment, human factor, training and competences. These five key areas are linked together. Without policies there are no guidelines for equipment facilities - simulators, jurisdiction, and training content to obtain standardized competence concerning e-navigation, by the navigators.

Policies guidelines are frequently requested by the respondents. Clarification of the definition of e-navigation is urgently needed. Communication of this progress and changes is needed, to be able to plan education and training in advance. Policies are governing the training activities, directly or indirectly, by influencing which equipment and who has access to participate in training, the content of training and the result - what competences/skills are required. Well-known and important in this evolvment are organizations such as the IMO, IALA, IHO etc. Activities mentioned are data protocol, regulations, harmonizing, minimum-levels, model courses, port reporting, route-planning, performance, structures of school-systems and documentation of skills. It was revealed that shipping companies do not use the required installed equipment on the vessels because of the adopted policies.

Equipment such as simulators with accessories, is described and shows differences in technology and the amount of facilities in different training situations with respect to the respondents' descriptions. Cost of equipment is a big concern, with no, or limited guidelines for the future. Negotiation with manufactures is an obstacle. With improved guidelines these situations and the possibilities would be more manageable and could give other opportunities in education and training, to the respondents. Validation of equipment, hardware and software vs. model-courses, and questions regarding functionality, access, individuality vs. fixed mode, transmission, automatic updating at

vessels and simulators, backup, time frame, AIS, VTS, integrated bridge simulators and chart view vs. paper chart are mentioned.

Human related e-Navigation questions are about access to training, attitudes regarding the new technology and potential for the future and human factors training as BRM, CRM, emergency, group-interaction, communication between ship to ship and ship to shore, and how to cope with stress and failure. Students' prior experiences and future work give rise to the need of a flexible training-model and content. Teachers' qualifications also need to be further explored.

Training in e-navigation and its results can be observed through different perspectives – as learners, shipping companies, educational facilities and authorities or equivalent. Cost has a huge effect on training, and shipping companies reduce training in e-navigation promptly when there is a weaker market. This has an impact on competencies, recruitment, profits and investments in training facilities and possibilities for different kinds of changes. Reflections exist about language barriers and a need for translation, hand-over of bridge-screens, visual-checks, port services and time schedule of charge and discharge vs. e-Navigation, terminology, time of training (need of 1week-1day dependent on daily profession, vessel and culture), on-board activities and training, reporting and information exchange, track-holding of frequencies and e-certificates. Advantages vs. disadvantages of e-Navigation were important issues to be included.

Competencies of e-Navigation are dependent on the competence of both the teachers' qualification and the students' set of skills prior to and after e-Navigation training. The definition of e-Navigation regulates and determines the range of competence to be achieved. E-navigation certificate is requested for such an undertaking. It's an exchange of knowledge in an interactive environment during the training. Experiences and reflections are important tools in the understanding of pros and cons in e-Navigation, this is interesting from the point of computer skills and interpretation of circumstances. Several teachers mentioned that more experienced seafarers compensated their lack of "typing" on the computer with basic knowledge about navigation and awareness. The younger seafarers, often high skilled in typing, take action without or with inferior awareness of circumstances and reflection concerning failures.

3.5.4 Conclusion

The semi-structural qualitative interview among experienced Mariners working as e-navigation teachers at educational facilities in six countries in the North Sea region has presented gaps and

needs linked to services, education and training. One teacher/country (Denmark, Germany, Netherlands, Norway, Sweden and the United Kingdom) was selected at random at maritime training centres and interviewed by telephone or Skype.

A clarification of the definition of e-Navigation and the future progress is urgent to manage the subject. Organizations such as IMO, IALA and IHO (etc.) are important actors in this development. The need for policies regarding e-Navigation are crucial for managing several other factors as equipment, human operators, training and competencies. These factors are also dependent on each other. The ground level contains policies which give guide-lines to the next step with content regarding, both equipment and human factors at the same level and these three factors have an impact on the next step of e-navigation training with the final result of competence in e-navigation.

It was revealed, in this investigation, that shipping companies do not use required installed equipment at vessels because of the adopted policies. Different equipment and number of devices are used for training, according to responses and there is a need for guide-lines. Other aspects are validation, functionality and usability. In e-navigation, human factors needs to be dealt with in a serious way. It covers factors as access to training, to the design of training and awareness of human aspects and the need of reflection about situations. Communication between crew-vessel; vessel-ashore is an important aspect. All aspects need to be incorporated to increase the competence of e-navigation. Training shows a big variety considering the descriptions of the respondents. Lessons are different in structure, content and in duration. The reasons differ among participants. Quite often a question appears about the definition of e-Navigation. Model-courses are positive as guide-lines. Discussions occur between teachers about training, but on the other hand, one of the respondents did not want to hand over the course plan due to previous bad experiences of abuse.

Competence of e-Navigation is dependent on policies that give guidelines for devices, human operators and training. Without clarification regarding the definition of e-navigation, the content of competencies is uncertain and an e-navigation certificate is considered useful and requested.

This page is deliberately blank.

4 Reflection on and discussion of select e-navigation training aspects

This section presents the output from the research performed as case studies and presented hereunder as self-contained sub-chapters. Research engagement with academics, industry and stakeholders were performed in the project and partly presented at conferences, in a journal as well as a review article highlighting the state of art of the training for groups of end users.

4.1 Standardisation aspects of e-Navigation training

E-navigation aims to harmonise navigation systems and ultimately make the mariners' job easier, but its implementation will necessitate extensive changes to maritime training. In this article, Dr. Michael Baldauf of the World Maritime University, discusses the reasons for change, progress made so far, and further changes that will need to be made to reap the benefits of e-navigation.

In recent years, bridges have become increasingly 'smart' with a plethora of new equipment, systems and interfaces. New pieces of navigation equipment and sophisticated systems have been introduced both on-board and ashore, primarily to improve safety. New equipment such as Automatic Identification Systems (AIS), Voyage Data Recorders (VDR), Simplified Voyage Data Recorders (S-VDR), Integrated Navigation Systems (INS), Integrated Bridge Systems (IBS), and numerous others, are found on state of the art navigational bridges, providing the mariner with vast amounts of useful information. Indeed, some of these tools are mandatory for vessels from regions covered by the International Convention for the Safety of Life at Sea (SOLAS).

The advent of Electronic Chart Display and Information Systems (ECDIS) was a major cornerstone but, in order to ensure that all electronic equipment works and performs optimally, it must be integrated under an overarching framework - just as all of the instruments in a large orchestra need to be tuned and harmonised to produce a good overall effect. This is what e-Navigation, a concept developed by the International Maritime Organisation (IMO) together with the International Association of Lighthouse Authorities (IALA), plans to achieve by standardising navigational tools in an all-embracing, over-arching system.

E-navigation will bring together disparate systems, making the mariner's job easier and subsequently, enhance navigational safety and efficiency. It will connect ship and shore by powerful communication systems and help all the operators on board - captains, pilots, navigating officers, engineers, as well as the vessel traffic service (VTS) and search and rescue operators, to effectively fulfil the tasks they are responsible for.

4.1.1 Pre-e-Navigation Education and Training

Before e-Navigation, the introduction of new systems into shipping was accompanied by related training measures. The IMO laid down all of the minimum requirements for seafaring personnel in the International Convention on Standards of Training, Certification and Watchkeeping for Seafarers (STCW). Whilst this established the basic minimum requirements, Model Courses with specific training requirements were defined for special purposes and particular equipment. For example, the ARPA/Radar Model course or the ECDIS Model course, has become mandatory for navigators.

Manufacturers and suppliers of navigational and technical equipment offer specific training courses for users to support the effective operation and handling of their systems in practice, but these systems are not standardised and therefore neither is the training for them. Mariners may be able to use equipment from one manufacturer, but not from another. This could have an impact on their career progression, as their experience and training may not be interchangeable with those needed to operate other vessels. There are also significant safety implications of not being trained properly on the equipment they are operating.

4.1.2 The impact of e-Navigation

In order to get a more detailed view, the question of what impact, if any, the introduction of the e-navigation concept will have, will be discussed here.

ACCSEAS, a European project that is developing and implementing a practical e-Navigation test-bed to harmonise the exchange of electronic maritime information, has been assessing the impact of e-navigation so far by conducting interviews and simulation runs with experienced mariners. Over the last year, ACCSEAS has conducted several simulation sessions, putting mariners into a potential e-navigation environment with aspects such as the integration of route recommendation from a shore-based coordination centre. Mariners were also interviewed about their knowledge and training experience of e-Navigation.

The interviews showed that, whilst e-Navigation has a worldwide community, knowledge of the concept is still at a rather low level. Almost all of the interviewees had received no training in the concept of e-Navigation and the closest e-Navigation came to be mentioned was briefly as a part of BRM (Bridge Resource Management).

Most interviewees had learned about the concept from articles in industry magazines and journals, therefore most were self-informed rather than having undergone any specific training. More surprisingly, teachers and lecturers at recognised Maritime Education and Training (MET) institutions were not fully aware of e-Navigation. While interviewed mariners expressed their wish to be informed and educated before the introduction of the e-Navigation based new systems and concepts, most of the maritime universities, academies and other training institutions consulted said it is largely not a subject of training modules, lectures or other types of courses at all.

In this research, ACCSEAS found that ship operators would like to have harmonisation of alarms and warnings when navigating in shore-based monitored areas. For example, warnings triggered by a collision and grounding avoidance system ashore must be harmonised with the system on-board in order to avoid confusion and delay. As a minimum, the training and education of users both on-board and ashore should be complementary.

Interviewees also supported the idea of standardised human-machine-interfaces, which they think would help to make training more effective and efficient than it is today. Greater standardisation would mean that mariners are able to safely use systems, even if unfamiliar with them - much as the standardisation of cars has meant that anyone who has learned to drive can safely operate any model of car.

4.1.3 Conclusions to improve training

There has been little change in training since the concept of e-navigation was introduced. It is clear that new training requirements need to be implemented for e-navigation, which introduces new applications such as enhanced anti-collision displays, dynamic tidal and current information integrated into ECDIS, as well as completely new services like route broadcast and route suggestion services for enhanced traffic management and coordination.

Equally as important, navigators will need to be trained on the constraints of these systems, how to spot errors, and how to interpret warnings and alarms. Captains, pilots and navigators must be much more aware of the limits of any system used for navigation. VTS operators must take care when broadcasting information gathered from shore based sensor systems and inform the users of the reliability of the given information accordingly. This will hopefully combat an existing over-reliance on systems, which can cause mariners to miss important changes or warning signs.

It is likely to get harder before it gets easier as, before harmonised systems can be universally implemented, the e-navigation community will need to decide on the standards, enforce them, and ensure all mariners are trained on them. The long-term training implications of e-navigation, however, are positive. A higher level of standardisation of e-navigation systems will lead to more standardised training, and this will be easier for the e-navigation community to provide and enforce in the future, and simpler for the mariner to complete.

The role of the ACCSEAS project primarily is to assess where there are training gaps and understand how training can be improved and made accessible to the mariner. It aims to develop and offer supporting training materials for the services designed within the e-navigation test-bed and actively make these available to the shipping community.

4.2 E-navigation training issues to ensure and increase maritime safety

'Baltic Ace' – 'Corvus J', 'Almeria' and 'Lisco Gloria' four ship names each of which stand for a sample case of an accident: a collision, a grounding or a fire on board ended up in the successful evacuation of all passengers but the total loss of the ship – three sample accidents that recently happened and are in our minds when we think about the future of sea transportation. The International Maritime Organization (IMO) aims for safe, secure and efficient shipping on clean oceans. Research and technological development is looking for solutions to avoid accidents. However, although there are numerous sophisticated safety systems installed on board ships as well as ashore in dedicated traffic management centres in order to avoid such events or to minimize the consequences of any accident, the number of accident seems to constantly remain on a high level. Between 2004 and 2010, each year approximately 100 accidents happened only in the Baltic Sea. Are the safety systems not sufficiently appropriate to support captains, pilots and navigating officers? How can e-navigation help to increase safety and simultaneously contribute to make sea transportation more efficient and environmentally friendly? E-navigation is a holistic concept defined as

'... the harmonised collection, integration, exchange, presentation and analysis of maritime information on-board and ashore by electronic means to enhance berth to berth navigation and related services, for safety and security at sea and protection of the marine environment.'

One of the aims of e-Navigation is to harmonize and to standardise systems to ultimately make the mariners' job easier, therefore reducing the risks of collisions and groundings and to avoid pollution of the marine environment respectively. It should be realised by integrated on-board navigation

systems "that benefit from integration of own ship sensors, supporting information, a standard user interface and a comprehensive system for managing guard zones and alerts." It is quite obvious that such systems will have strong effects on safety of navigation and the protection of the marine environment as well.

In the last two decades a number of technological improvements addressing specific safety related aspects. New pieces of equipment and enhanced and sophisticated systems were introduced on-board and ashore as well to primarily contribute to more safety. We can mention e.g. Automatic Identification Systems (AIS), we can refer to the introduction of Voyage Data Recorders (VDR) and Simplified Voyage Data Recorders (S-VDR), on Integrated Navigation Systems (INS) and Integrated Bridge Systems (IBS) and many more pieces of equipment that are today state of the art. Maybe Electronic Chart Display and Information Systems (ECDIS) can be seen as one of the major cornerstones of all these developments and systems that have been introduced rather as sole and standalone systems but need to be integrated all together into an overall framework in order to make them working and performing at their best and to materialize the inherent potentials – like making all the instruments of an orchestra sounding perfect. The e-navigation concept is exactly about this and is to help the human operators on board – the captains, pilots, navigating officers, engineers or the VTS and SAR operators ashore to fulfil their tasks they are responsible for.

4.2.1 E-navigation – bringing together technical systems and human operators

E-navigation applications like e.g. enhanced anti-collision displays, dynamic tidal and current information integrated into ECDIS but also completely new services as e.g. route broadcast and route suggestion services for enhanced traffic management and coordination are about to be developed, demonstrated and tested. However, it is well recognized that training requirements will also rise. From on-going research it is concluded that there is a need to pay attention not only to the potentials of the new systems and their options to display and highlight safety related objects but moreover and particularly also to the constraints and the corresponding consequences for sophisticated presentations including processed and linked information and even warnings and alarms. The operators must be much more aware and must know about the details of the limits of any system used for navigation.

From research projects like e.g. ACCSEAS it has become obvious that the users wish to have more sophisticated harmonization of alarms and warnings when navigating in shore-based monitored areas. Warnings triggered by the collision and grounding avoidance system ashore and on-board must be harmonized in order to avoid confusion and unnecessary communication. The minimum

level of harmonization should be in using harmonized approaches when training and educating the end users. On the other hand as e-Navigation also addresses harmonized presentations, users support the idea of standardized human-machine-interfaces. Research clearly proves that standardisation helps to make training more efficient than it is today, when e.g. type specific training is required for certain pieces of equipment.

New technologies have to be integrated into the training programs. In the European ADOPTMAN project new enhanced manoeuvring support modules have been developed and tested in a ship-handling simulator environment and lead to the parallel development of new tools to enhance the training and education. E-navigation will not only make use of modern simulation-based functions but also will improve training and education as well. In the 'TeamSafety' project, a multi-dimensional simulator has been developed in order to improve team training for maritime safety related subjects for complex scenarios as e.g. a fire on-board a RoRo-Passenger-Ferry that also includes the actions to prepare the evacuation and coordination of the shore-based support.

4.2.2 Conclusion

The e-Navigation concept is obviously a driving force for safe, efficient and sustainable shipping in the future. It not only effects technical and technological developments but also maritime education and training. The research partners, dealing with the ambitious e-navigation concept, need to also consider the training issues. ACCSEAS and other e-Navigation related projects therefore continue their work with further surveying and studying the situation and want to develop ideas and derive suggestions and recommendations on how to design e-navigation training in order to materialise the benefits and to make the new services working efficiently from the moment of its introduction into the real world.

4.3 Training aspects of ECDIS use and e-Navigation

Almost three years into the mandatory introductory date of ECDIS (July 2012), we take note of Murray's seminal article in which he argues that ECDIS is a core component of e-navigation and, *'unless the industry gets ECDIS right, the chances are e-navigation won't become a reality'*. He begins the article by reflecting upon how we reached the point where we are today in 2014 and reminds the readership of the high expectations from ECDIS in terms of enhanced navigation safety and environment protection and whether or not the technology could deliver upon the promises. He raises several pertinent issues while mapping out the current scenario in terms of ECDIS and e-navigation. The key issues relate to the 'design limits' of ECDIS, 'multiple meanings' of ECDIS, the

'two halves' (ship and shore), training issues and goes on to discuss the probable solutions to prevent disorder. Murray opines that more than just training and maintenance are required in the case of ECDIS, given the sheer numbers of the different types of ECDIS that could impact transfer of learning. Murray suggests that an e-navigation training module of 3-4 hours would suffice. He delineates the different meanings of e-navigation and motivations for the diverse stakeholders – IMO, IALA, administrations, VTS and the manufacturing industry. He points out that the ECDIS has been developed without the input of the key stakeholder; the end user – the seafarer. Murray argues for the management of the lifetime expectations of the shipping industry. He calls for enhancing chart accuracy, bringing hydrographic up to date and mitigating the risk of GPS interference. He argues that for e-navigation to be automated and robust, the critical waterways require terrestrial support to GPS. Murray calls for a, *'global roll out of a common set of standards, interpretations, interface and above all working practice'*. He justifiably argues that *'the technology was or perhaps still is not ready'* and ends the article by rhetorically asking the reader to consider, *'whether we are getting closer to the user need and importantly ... whether the technology is ready?'*

Murray has raised several issues in his article. We take cognizance of them and make an observation on his point, *'that there is no comparable shore based equivalent to the STCW code'*. We observe that the terrain is not barren on the shore side and we need not start from scratch as there are several exemplar model courses in existence for the shore side, some of which are enumerated below.

1. V-103 Ed 2 On standards for training and certification of VTS personnel 12/2009
2. V-103/1 Ed 2 Model Course - VTS operators basic training 12/2009
3. V-103/2 Ed 2 Model Course - VTS supervisors - Advancement training 12/2009
4. V-103/3 Ed 2 Model Course - VTS on the job training (VTS operator and VTS supervisor) 12/2009
5. V-103/4 Ed 2 Model Course - VTS on the job training instructor 12/2009
6. V-119 Ed 2 For the implementation of Vessel Traffic Services 12/2009
7. V-120 Ed 1 On Vessel Traffic Services in inland water 06/2001
8. V-127 On operating procedures for Vessel Traffic Services 06/2004
9. V-128 On operational and technical performance requirements for VTS equipment
10. V-136 Participation in the World VTS Guide 12/2007
11. 1014 Ed 2 On accreditation of VTS training courses 12/2009
12. 1017 Ed 1 On the assessment of training requirements for existing VTS 06/2001
13. personnel, candidate VTS operators, revalidation of VTS operator
14. certificates
15. 1026 Ed 1 On AIS as a VTS tool 12/2001

16. 1027 Ed 1 On Designing and implementing simulation in VTS Training at Training Institutes /
VTS Centres 06/2002

5 Training Needs and Gap analysis for selected ACCSEAS solutions

5.1 General remarks

In the frame of the ACCSEAS project a number of simulation trials for purposes of studying the technical feasibility and demonstrating operational improvements have been conducted at several locations using different kind simulation or demonstrating infrastructures as feasible and appropriate.

Even though, it was not possible to test and study training needs and gaps for all of the suggested ACCSEAS candidate solutions. While technical feasibility was realized for most of the solutions, operational integration was not subject in every case for the suggested solutions.

On the other hand, also some of the functions are very futuristic and visionary and need to have a kind of a common sense for regional and international approval, e.g., when new functions and functionalities are extending existing services of VTS.

However, end users needs are very much depending on the operational and technical environment in which new services needs to be provided. That is why this report focuses on a few selected cases of well developed; already quite mature technical solutions with a clear tendency of acceptance by end users.

5.2 Tactical route suggestion and tactical route exchange

5.2.1 Introduction

As stated in [2] problems with communications are the most prominent causes of collisions at sea. Most frequently there is a lack of communication and a subsequent misinterpretation of information, particularly information about ships intentions (Porathe, et al., 2013). The denser the traffic the more potential there is for collision situations to develop. In a future North Sea with reduced sea room, traffic management might become an issue (methods for traffic management is being investigated by the MONALISA project). But even with traffic management, close quarter situations are bound to become more common than today and communicating intentions might become even more important.

In order to reduce and minimize occurrence of unwanted situations and events ACCSEAS suggests further studies of this tactical route exchange service. During simulation trials described above scenarios for possible unintended consequences of such a services have been studied.

5.2.2 Simulation scenarios

For the purposes of identifying training needs experienced navigators, pilots and VTS operators were invited to simulation trials. In the frame of these trials scenarios were provided for demonstration purposes specifically for the use onboard an operating vessel.

Aims, objectives and content of simulation trials are repeated here for purposes of completeness once again.

Desktop Simulation

1. Demonstrator using a pair of lap-top based EPDs (side effect of test process)
 - a. Office based demo **without** full bridge simulator
 - b. Demonstration at conferences

Bridge Simulation

1. End Goal: "Vessel broadcasts intended (active) route."
 - a. Mariner A activates route plan mode
 - b. Mariner A plans route
 - c. Mariner A sets planned route to active route
 - d. Active route is broadcast
 - e. Mariner B selects vessel on display
 - f. Mariner B selects "Display Active Route" option from vessel drop down menu
 - g. Mariner A's active route is displayed on Mariner B's EPD

Note that the COLREGS will need to be considered very carefully in order to ensure contravention is avoided.

2. End Goal: "Vessel broadcasts intended (active) route under conditions of GNSS interference."
 - a. GNSS input to Multi-source receiver aboard Mariner A's vessel is denied
 - b. Multi-source receiver switches to secondary system and flags a PNT alert
 - c. Mariner A activates route plan mode
 - d. Mariner A plans route
 - e. Mariner A sets planned route to active route
 - f. Active route is broadcast
 - g. Mariner B selects vessel on display
 - h. Mariner B selects "Display Active Route" option from vessel drop down menu
 - i. Mariner B notes PNT alert from Mariner A's vessel
 - j. Mariner A's active route is displayed on Mariner B's EPD

- k. Mariner A notes PNT alert from Mariner B's vessel

Vessel and Shore Based

1. End Goal: "Vessel broadcasts intended (active) route."
 - a. Mariner A activates route plan mode
 - b. Mariner A plans route
 - c. Mariner A sets planned route to active route
 - d. Active route is broadcast
 - e. Mariner B selects vessel on display
 - f. Mariner B selects "Display Active Route" option from vessel drop down menu
 - g. Mariner A's active route is displayed on Mariner B's EPD

2. End Goal: "Vessel broadcasts intended (active) route under conditions of GNSS interference."
 - a. GNSS input to Mariner A's multi-source receiver is denied
 - b. Multi-source receiver switches to secondary system and flags a PNT alert
 - c. Mariner A activates route plan mode
 - d. Mariner A plans route
 - e. Mariner A sets planned route to active route
 - f. Active route is broadcast
 - g. Mariner B selects vessel on display
 - h. Mariner B selects "Display Active Route" option from vessel drop down menu
 - i. Mariner B notes PNT alert from Mariner A's vessel
 - j. Mariner A's active route is displayed on Mariner B's EPD

5.2.3 Training Needs and Gaps

Training needs and Gaps were derived by focus group discussions with the participants of the simulation trials after completion of exercise runs. The discussions and their main outcome has been reflected and described in great detail in chapter 3.2.1.

One important outcome with respect to the development and establishment of related training for end users it is concluded from the trial results and the gathered feedback from experts that a high level of acceptance can only be expected if an appropriate demonstration of new services is possible. Appropriate integration in this context means that new technology is completely technically integrated into the (simulated) working environment. Makeshift solutions or any provisional

arrangements will contribute have rather negative end users feedback. The provided simulation environment for the intended route exchange and route suggestion was almost perfect.

Beside technical integration, moreover, also clear and concrete operational procedures must be provided when new functions and functionalities are subject of tests and training as well.

A special item that became obvious with respect to training of the use of route exchange facilities was compliance with COLREGS. Mentioning this proves the request for integrated training within the usual physical and operational work environment. Suggestions for specific training courses, dedicated to e-Navigation subjects focusing only on selected new functions were not supported much.

5.3 NoGo Area Service

5.3.1 Introduction

This paragraph is provided by Chalmers University of Technology, here after denoted Chalmers, input to the Training Need Analysis (TNA). Chalmers responsibility is to perform the TNA for the operational service No-Go-Area (NGA), described in [ACCSEAS]. The aim of this service is to support the mariners with automatic calculated tidal information for UKC management. The No-Go area service automatically provides vessels with information on vessel specific No-Go areas based on wanted UKC, detailed bathymetry and tidal information.

5.3.2 Method

The TNA reported in this document is based on JSP 502, which is a method developed by the British armed forces to support procurement processes and is applicable on operational equipment, software projects and purchase of training equipment and service. The methodology is described as a whole in the ANNEX 1. The TNA process comprises of three phases:

- TNA Scoping Study;
- TNA Development; and
- TNA Post Project Evaluation.

In this analysis only the TNA Development Phase has been used. This phase can be further divided into three sub-phases:

- operational task analysis;
- training gap analysis; and
- training options analysis.

5.3.3 Operational Task Analysis (OTA)

This first paragraph gives an overview of the NGA service in its operational context. The nautical work on-board a ship follows the navigation process, which consists of four main phases:

- Appraisal;
- Planning;
- Execution; and
- Monitoring.

A ship's voyage needs to be planned in advance and it is the master's responsibility that the plan is made and followed. The actual planning is often delegated to another bridge officer normally the second officer.

"The intended voyage shall be planned in advance, taking into consideration all pertinent information, and any course laid down shall be checked before the voyage commences." (STCW, 1995). Further, a voyage plan should cover the complete voyage berth-to-berth and describe the most favorable route taking into account; predictable problems and hazards along the route. In the execution phase, time is put on the plan, adapting ETA to the different Waypoint (WPT) along the route. In doing so, one important input is the Under Keel Clearance (UKC) requirement in relation to tidal information. During the monitoring phase, the Officer on Watch (OOW) monitors the progress of the ship.

Almost all voyages will encounter areas along the route with shallow waters. This could for instance be port areas, rivers, canals, narrow straits and other offshore and coastal areas.

In (Swift, 2004) it is stated "except when alongside or threatened by another ship, the nearest danger is inevitable vertically below", hence the master needs to be convinced that a certain UKC is maintained during all phases of the voyage. In some cases, authorities or cargo owners put requirements on minimum UKC. In any case, the master or the shipping company needs a navigation policy stating what UKC to use for a particular ship and for different conditions. Factors that are influencing the selection of UKC can be, (Anwar, 2006):

- Uncertainties in charted depth;
- Uncertainties in the vessel's draught, which will change during the voyage;
- Dynamic squat;
- Tidal surge;
- Heavy weather and sea state; and
- Depth information.

Bathymetry information is given in the nautical chart. Today, we have two types of nautical charts:

- Paper charts; and
- Electronic charts.

The depth values are given with respect to a certain reference level denoted as the chart datum. One problem is that different chart datum is used in different geographical regions. In some cases different chart datum are even used within the same geographical region.

The presentation of depth information in the paper chart has a number of limitations, e.g.:

- Cluttering of information related to e.g. spot soundings;
- Cannot change the displayed information level;
- Depth contours for several depths are visualized;

In the electronic chart, as part of the ECDIS system are more user friendly due to, e.g.:

- Selection of information level: base; standard; and customized; and
- Selection of safety contour.

As pointed out in (ACCSEAS) some limitations still exists in today’s use of safety contours in the ECDIS. The safety contour can only be selected from a limited selection of depth contours.

The aim of the NGA service is to support the mariners with automatic calculated tidal information for UKC management. The service automatically provides vessels with information on vessel specific No-Go areas based on wanted UKC, detailed bathymetry and tidal information. The No-Go areas are presented on the ship’s tactical display, in this project implemented in the E-navigation Prototype Display (EPD), and are updated on demand from the user. The No-Go area is defined in the figure 4, below.

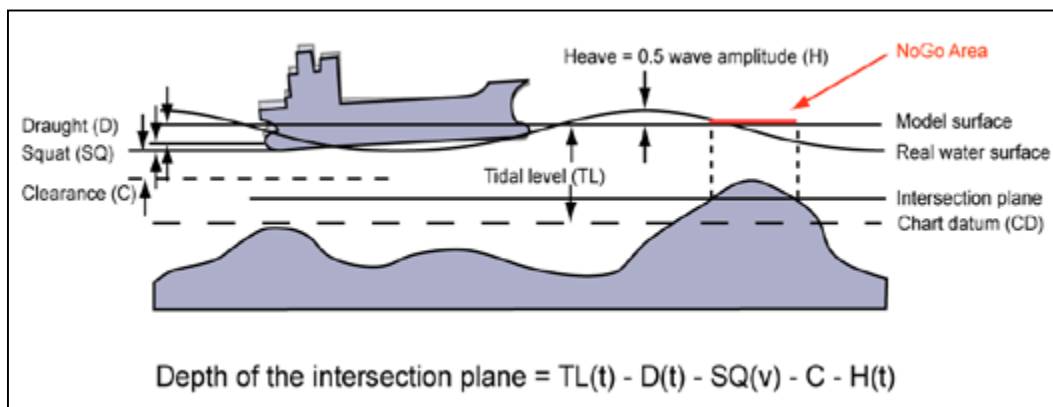

Figure 4: Definition of the NGA, (ACCSEAS).

The main operational sequence in using this service is:

1. A query including a geographical area, applicable time and wanted UKC, are send to the shore service provider.
2. The shore service provider has detailed bathymetry data and tidal information.
3. The shore service provider returns information on vessel specific No-Go areas and these are displayed on Ship’s tactical EPD.

One expected benefit with this operational service is that it might lead to cognitive off-loading for the officer on the bridge and thereby to reducing risks of errors leading to groundings or unnecessary close meetings.

5.3.4 Training Gap Analysis (TGA)

Training and education within the maritime sector is controlled by international standards mainly adopted by the IMO like the STCW (Standards of Training, Certification and Watch keeping), these refer to training and education on a general level over several areas some are type specific with regards to certain operations and vessel type. As being described in the paragraph above the officers onboard need knowledge about tidal water and tidal currents. Rudiments on this can be found in Chapter II “Standards regarding the master and deck department”:

Function: Navigation at Operational level:

“Ability to determine the ship’s position by use of:

.3 dead reckoning, taking into account winds, tides, currents and estimated speed.

“Thorough know ledge of and the ability use, tide tables, ..” (STCW, 2011)

Function: Navigation at Management level:

“Voyage planning and navigation for all conditions by acceptable methods of plotting ocean tracks, taking into account, e.g:

.7 areas of extensive tidal effects” (STCW, 2011)

An example on a typical curriculum is based on three course in Chalmers’ Master Mariner Program:

Basic course: Tidal water and currents:

- Tidal theory
- Navigation in waters affected by tidal levels and currents
- Manual calculations of tidal levels and currents
- Practical simulator exercise sailing in under the influence of tide currents

Ocean Navigation:

- Tidal calculations in the passage planning phase

Bridge management:

- Practical passage planning including tidal calculations
- Practical exercises in ship simulator using a segment of planned route in tidal water
- Practical examination in simulator using a segment of planned route in tidal water

It is also important to mention the basic ECDIS training course, which gives an in depth understanding of the ECDIS theory and practical use.

Computer based systems for tidal calculations and passage planning is introduced in the above mentioned courses.

Introducing a new navigations service like the NGA service needs additional dedicated basic training and familiarization of the new functions introduced in an electronic chart or ECDIS. This should, in the future, be part of for the basic course in tidal water and currents and a bridge management course.

This basic training needs to include the following parts, here introduced as training requirements:

- Measurement principle or service calculations in order to fully understands potential; data errors, pros and cons with the system or service;
- Data checking, how to perform integrity checking of the information;
- Familiarisation with functions and the display outline; and
- Operational methods and procedures used in the navigation process, hence taking into account all steps; appraisal, planning, execution, and monitoring.

5.3.5 Training Option Analysis (TOA)

Based on the training requirements listed above, a recommended solution is presented below. First, it is recommended that when an NGA service is introduced, mariners that will use the service is attending an additional training module. For longer term, training of the service should also be introduced in the compulsory parts of the Master Mariner Program both on operational level and master level.

Training requirement	Recommended training solution
Measurement principle or service calculations	Lecture or high quality CBT
Errors and Pros and Cons	Lecture or high quality CBT
Data checking	Lecture or high quality CBT Simulator exercise
Familiarisation with functions and display outline	High quality CBT Ship simulator exercise
Operational methods and procedures	Ship simulator exercises

Table 1 Recommended training solutions for the different training requirements.

Lectures where an instructor are explaining the theory, errors, data checking, introducing methods and procedures are very beneficial, especially if the class is rather small. The instructions can then be followed by interaction between the class and the instructor.

Computer Based Training (CBT): is a cost effective way of introducing new systems and services. It should be pointed out that the CBT tool needs to be of high quality appreciating pedagogic methods and means. However, this type of training will lack the interaction with an instructor.

Simulator exercise is used to train the practical and soft skills of using the service in a realistic context together with all other procedures etc.

For this type of simulations advanced ship simulators are recommended equip with modern bridge equipment including the new service. The simulators are recommended to be of class A or B.

5.4 Augmented Reality and Head Up Display

5.4.1 Content, aims and objectives of the new service

Mariners are traditionally focused on visual identification of targets. The COLREGS are based as well on visual recognition of a target and its relative course and speed. Therefore the strategy and action of the Watch Officer (WO) to avoid collision is well trained and experienced and, apart from low visibility situations, is always based on visual observation.

Although much effort is taken to minimize the risk of collision, accidents still happen. Accident investigations show that fatigue and human error play an important role in the cause of accidents. Once the WO is distracted from watch keeping, the WO will no longer react according the COLREGS. Although Automatic Radar Plotting Aid (ARPA) can generate an audible alarm as “Collision Warning,” distracted mariners will have difficulty to identify the dangerous target and start acting in order to avoid collision in the little time between the alarm and the critical Closest Point of Approach (CPA). Setting the alarm threshold too wide, in order to have more time to react, is considered disadvantageous because it might generate unwanted alarms.

Augmented Reality (AR) and Head Up display (HUD), in principle, has two functions, one is to alarm the mariner by means of an audible signal together with a visual signal pointing towards the dangerous target; the other is a HUD of operational information. Operational information is considered in the widest meaning of it.

The functionality of AR is to point directly and visually in the direction of the dangerous target, thus inducing an immediate focus for the responsible officer of the watch (OOW) on a dangerous target.

Apart from this 'alarm of last resort' function, AR can also function as a display of operational information. Once the information of route exchange or Marine Safety Information MSI, or NoGo-area, which are deemed to become e-Navigation services or even products, is available, displaying this information on a HUD, e.g. bridge window or OOW cocoon, seems to be an effective combination of electronic navigation and the traditional focus on visual identification and lookout.

5.4.2 Test concept

The drafted concept for the test-bed comprises of a Norcontrol ships bridge simulator with an own ship and an area with targets transmitting AIS messages. The stream of AIS messages is read through a COM port by the laptop on which the Augmented Reality application is running. Filtering is done to overcome the discontinuity in time of transmitted AIS messages because all targets send their messages in different time slots and in different rates depending on their status, speed and turn rate. The goggle's position and direction of view is measured by a 'Tracker'. This device consists of a motion sensor and a system that locks at a set of visual markers, i.a. locators, on the bridge.

The aim of this tracker is to provide information of the observers' view direction in order to calculate the relative position of the projected information, e.g. the red box in which the dangerous target is shown.



Figure 5: Sketch of augmented reality, showing dangerous target, area to be avoided and route suggestion

Trials have been performed to test the technical feasibility of the developed concept which was successfully demonstrated.

A crucial role in respect to navigational watches is the link of AR and HUD to any algorithm for identification of a dangerous target or providing decision support for manoeuvring or actions to be taken.

On basis of comprehensive task analysis IMO's Performance standards for Integrated Navigation Systems (MSC.252(83)) provides a essential navigational tasks that needs to be supported by an INS.

One of which is collision avoidance and another is alert management to which AR and HUD may contribute accordingly.

In global terms alert management shall contribute to harmonization of priorities and classification and on the other hand it is to enhance the handling, distribution and presentation of alerts. IMO defines three levels of alerts – first is 'Caution' (lowest level; as a kind of a signal that there is a situation with certain deviation from usual (safe) conditions) secondly 'Warning' (requiring immediate attention of the bridge team) and finally, highest level of an alert 'Alarm' (requiring immediate action to avoid any hazard to navigation. AR and HUD provides a perfect environment to realise this requirements

5.4.3 Training aspects

Basic findings are that training is needed to get accustomed to the overlay of a dynamic image over the real outside view. Personal observation learned that focusing on the dynamic virtual image was not very difficult when the real background was kept steady, however, focus was immediately shifted to the background when this background got dynamic e.g. by moving your head in another direction. However, this also requires further research into the impact of such enhanced technologies on human behaviour in general and on the collisions avoidance task as addressed here in particular.

Beside the use and handling of the goggles and its calibration and initialization, of course, training also needs to cover algorithms and procedures implemented in the expert system to trigger a warning or an alarm or to highlight certain areas of concern. End users need to know how to configure the system and to learn about the potentials but also the limits of this kind of a support service.

5.4.4 Suggestions for the development of a appropriate training module

As stated already earlier, it is very obvious that AR and HUD if accepted for e-Navigation and ship navigation in general, do not need an extra training course designed for carefully and responsible use of the new technology.

AR and HUD is a typical case of applying modern technology with need for familiarization with handling, potentials and limits of the provided functions. A training module integrated into existing courses like e.g. Radar/ARPA or AIS courses is proposed as efficient measure to provide end users with necessary knowledge. The training module suggested shall provide theoretical background, familiarization with handling and applied use for operational tasks of the OOW.

By now, the training gap rather consists of the first two subjects while its application into collision avoidance can be trained in regular simulation exercises of the exemplarily mentioned courses but also in other courses related to bridge operation, bridge management and so on.

AR and HUD can easily be integrated even into existing simulation exercises used for training of collision avoidance under conditions of good and restricted visibility. Existing simulation training scenarios can be used for demonstration purposes by conducting the exercises with and without the new option and further on include events that require handling of AR and HUD facilities adapted to the needs of a specific traffic situation.

Emphasis of training, however, needs to remain with the basics of collision avoidance (rules and regulations, situation assessment, decision making and taking action).

5.5 Dynamic Predictor

5.5.1 Content, aims and objectives of the prototype/service

Dynamic predictor is a feature that can be used to see the vessel future position for the next few minutes. In the earlier EfficienSea project predictor exchange was tested in collision avoidance application, but little or no use for the exchange was found yet.

SSPA Dynamic predictor have been successfully used on vessels operating on their own in berthing operations to assist the master in predicting the ships behaviour reducing risks of hard landing or collision with berth, ramp or dolphins. The dynamic predictor takes external wind and current forces into account but no other external forces. To add the forces provided by a tug is assumed to make the dynamic predictor usable also on vessels requiring tug assistance. It is also assumed that an exchange of predicted positions between tug and ship is useful in the manoeuvring.

Within ACCSEAS exchange of predictions is suggested for tug boat operation and studied if it is useful for ship to ship operations like tug boat assistance.

The AIM was to find out if dynamic predictor exchange and tug force exchange is of good use for manoeuvring a ship with tug assistance. Identifying risks and opportunities with exchanged predictor information and tug forces is of great importance.

Dynamic predictor takes input parameters from the ship and weather, but not from external forces like tug boat, fenders, dolphins etc. Including external forces will improve the predictor performance.

5.5.2 Implications for Dynamic Predictions

Intended model use of dynamic predictor for tug operation is for specific purposes and use cases. Once a tug comes close to the ship it is supposed to assist a wireless link for predictor exchange will be established. Once established the tugmaster will see the ships predictor contours and the tug will

send the forces to the ships predictor. It is of interest to test if the tugmaster have good use of seeing the predictor and if the officer in charge of manoeuvring the ship has use of the improved accuracy achieved by the tug forces input.

5.5.3 Simulation-based tests of the candidate solution

This section describes the proposed scenarios for demonstration purposes including those that can be demonstrated aboard an operating vessel, and those that should more appropriately demonstrated in simulation.

Desktop Simulation

Testing of interface and portrayal will be done internally in desktop simulation using SSPA Seaman simulator. Desktop simulator, or a portable bridge simulator can be used for demonstration. The test bed was set up in cooperation with DMA to incorporate and use the Ship EPD as main chart display.

Bridge Simulation

Training and Demonstration: Implementation within bridge simulator. Tests in bridge simulator is focusing on the operational service. For the tests SSPA SeaMan simulator was used. The setup used the 330 degrees bridge. In the consoles the main chart was the Ship EPD developed by DMA, the second chart display showed the chart in the open source software Open CPN. The third display show the ships conning display, including rudder, speeds, engine rpm, wind speed and direction. The radar was not used in the tests of the predictor operational service.

Tests performed

1. As today's operation. No dynamic or simple predictor used. Normal weather conditions.
2. Dynamic predictor without any external input.
3. Dynamic predictor with true external forces from tug.
4. Dynamic predictor with disturbed external forced from tug.
5. Use of a simple predictor using speed and accelerations only. Exchange of predicted position.

Arrivals and departures was tested

The ship used was Coral Energy in loaded condition.

LOA	154.95	m
LPP	146.67	m
Beam	22.70	m

° Draught loaded (LNG)	7.35/7.35	m
Draught ballast	5.69/4.69	m
Dead weight	8710	ton
LNG	15600	m3
Main engine	7800	kW
Service speed	15.8	knots
Max speed	18.7	knots
Propulsion	Controllable pitch propeller (119 rpm, 5.4 m)	
Bow thruster	850	kW (out of order)
Rudder	Conventional semi-spade	with max rudder angle 45

To force extensive use of the tug the bow thruster was disabled.

Harbour area and tug

The port of Gothenburg quay 518 is the port of destination or departure. For the simulation trials a 150 ton bollard pull ASD tug was available and was operated by the simulator operator. Snapshot from the harbour area in ECDIS-format and the tug are given in the figures below.



Figure 6: ECDIS snapshot of Harbour area (left) and tug boat (right) used in the simulation trials

In the simulation scenarios influence of wind was implemented with SW gusty wind of 10m/s is present in all simulations. For arrival a starting speed of 5 knots is used, the starting position is in the fairway some hundred meters west of the harbour. No other ships are in the harbour.

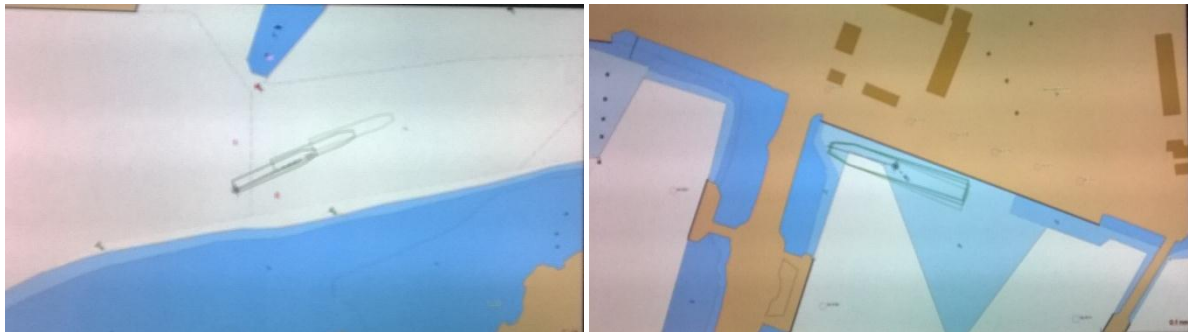

Figure 7: Initial and departure position (alongside quay 518) for the target ship in he trials

5.5.4 Simulation-test results

Arrivals

Table 1, time from start of simulation to first touch of the quay

Predictor type	First simulation		Second Simulation	
	Time (min)	order	Time (min)	order
No predictor	13	5	15.4	1
Simple predictor	11.7	2		
Dynamic Predictor without tug force	15	4	11.4	2
Dynamic predictor with disturbed tug force	12.1	3	13	3
Dynamic predictor with true tug force	17.8	1	10.7	4

Table 2, transverse speed the time step before first touch of the quay, Fat value is the landing value

Predictor type	First simulation		Second Simulation	
	Fore	Aft	Fore	Aft
No predictor	0.2046	0.0166	0.1216	0.1355
Simple predictor	0.0422	0.3099		

Dynamic Predictor without tug force	0.0988	0.3708	0.0829	0.3721
Dynamic predictor with disturbed tug force	0.1038	0.2266	0.1493	0.0330
Dynamic predictor with true tug force	-0.0014	0.1253	0.3034	-0.0602

Departures

A few departures were also tested. The evaluation criterion for the trial is time from the tug pulling 20% or more up to a point is passed on the way out of the harbour.

The departure times were between 8.4 and 9.9 minutes and no correlation could be found between the predictor types.

5.5.5 Comments, conclusions and outlook

The pilot manoeuvring the ship thinks the predictor is useful and helps the manoeuvre, but he did not use the predictor very much the last minute before landing on the quay, transverse speeds was more interesting in the latest part. He thinks the situation awareness and communication between the master and the pilot will improve with a dynamic predictor. Earlier in the project, some tug masters gave input on what they think about seeing the ships dynamic predictor. The conclusion is from these interviews that the situation awareness is improved by getting indication of rate of turn and how the ship moves.

None of the measured parameters gives a clear indication that the dynamic predictor with tug forces included makes the manoeuvre safer or more efficient. Maybe the time between first and second simulation indicate the predictor assist in learning the ships behaviour.

One comment from the Pilot was that the predictor might be more useful on a large vessel, like a VLCC.

Vessel Based test-bed (Future option)

If the simulator evaluation indicates the predictor exchange is a useful operational service a test on-board a vessel can be performed focusing on accuracy and communication links.

Here we see some problems of finding candidates test-bed vessels. Stena line ferries with installed predictors do not use tugboats. Installing and tuning a dynamic predictor is quite time consuming. The findings from the simulations will show if a simple predictor is useful, if this is the case full scale

tests with simple predictor exchange can be performed. This is not possible within the budget for ACCSEAS.

5.5.6 Results and conclusions from studies into general use of dynamic predictions

There are a number of further applications of dynamic predictions under development. From results gathered from literature review it can be summarized that related training modules need to address careful familiarization with the implemented function.

Simulation-based exercises should be used for demonstrating effects and impacts of any kind of disturbances to give the trainee sufficient overview on potentials and limits of such dynamic predictions.

Emphasis shall be laid on the clear distinguishing of existing static predictions, known from ARPA vectors, curved head lines as provided by some manufacturers of ECDIS and even the differences in the dynamic predictions specific to the manufacturers technological background and algorithms.

In the same way as mentioned for the other considered solutions, such training module can be integrated into existing courses, as e.g. an ECDIS course (as ECDIS seems to be the main display providing such functionality), Radar/ARPA course or Dynamic Positioning and others.

5.5.7 Outlook

So far and also within the ACCSEAS project dynamic predictions have been studied in respect to onboard use for manoeuvring support. There is a huge potential for application of dynamic predictions to all kind of manoeuvring tasks including the planning of complex manoeuvres but also the monitoring of plans in respect to safety margins and efficiency.

In this respect dynamic predictions shall also be further investigated in respect to its potential for enhanced shore-based services. So far monitoring of manoeuvres does not belong to duties of any shore-based operator yet. However, availability of data and technologies provides the environment for enhanced monitoring of vessel traffic in coastal areas or even when manoeuvring in port approaches and harbour basins for instance, if detailed manoeuvring plans can be provided electronically and exchanged between ship and shore-side operators.

This page is deliberately blank.

6 Draft material for sample training module ‘Dynamic Prediction’

6.1 Introduction

This chapter provides conceptual draft material for a training module dedicated to the supportive use of the suggested ACCSEAS candidate solution of dynamic predictions for selected use cases of ship navigation. The material and suggestions are not specifically focussing on tug boat operation but on the use of dynamic predictions in a wider sense of a more general approach.

6.2 The need for integrated use of dynamic predictions

Dynamic predictions have a huge potential for specific use cases to ensure safe, efficient and sustainable ship navigation. Manoeuvring of ships is and will be a human centred process despite of expected further technological developments. Most important elements of this process are the human itself and the technical equipment to support its task (see Figure below). However, most of the work is to be done manually because even today nearly no automation support is available for complex manoeuvres. Even worse, the conventional manoeuvring information for the ship officer is still available on paper only: the ship manoeuvring documents are mainly based on the initial ship yard trials or on some other selective manoeuvring trails for specific ship at certain environmental conditions - with only very little chance to be commonly used in the overall ship handling process situations effectively.

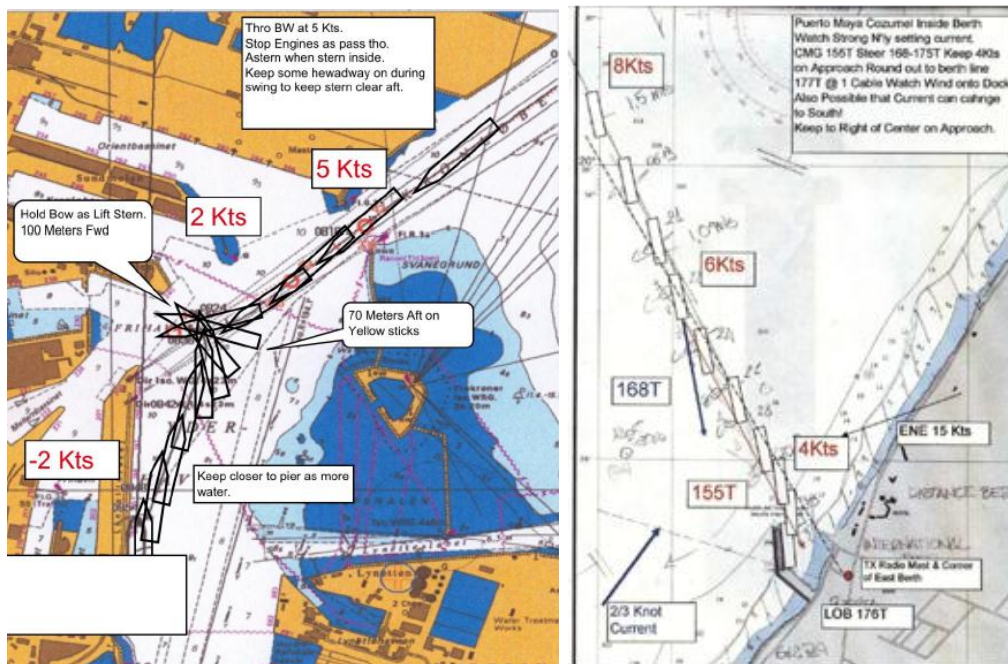

Figure 8: Samples of two plans for berthing a ship in a harbour

Up to now there was nearly no electronic tool to demonstrate manoeuvring characteristics efficiently or moreover to design a manoeuvring plan effectively. Even in briefing procedures when a pilot embarks a ship and according to requirements and good seamanship he is discussing and negotiating the plan potential manoeuvres to get to the next pilot station, an anchorage position, a lock or even the foreseen berthing place.

However, due to the new further developed demands there is a need to prepare harbour approaches with complete berth plans as e.g. when the pilot enters a ship to collaborate with the Bridge Team and moreover specifically in companies with high safety standards like cruise liners. These plans are necessary to agree on a concept and ensure common understanding of the plans within the bridge team and also for the discussion and briefing with the pilot. The plan for the potential manoeuvres must be developed– but still in a contemplative way by thinking ahead – only drafted on paper or described by self-made sketches and short explanations. The plans are made by hand on paper charts or on a printout of electronic chart interface. Dynamic prediction can change the situation by making use of enhanced ICT and sophisticated computer-based programs even integrating sensor systems of an INS.

6.3 Systematic approach manoeuvring

Very generally ship manoeuvres can be divided into routine manoeuvring and manoeuvring in safety-critical and emergency situations. This division can be further elaborated by considering different sea areas where manoeuvres have to be performed: e.g. in open seas, in coastal waters and fairways as well as in harbour approaches and basins. Routine manoeuvring in open seas covers ship-handling under normal conditions, e.g. in order to follow a planned route from the port of departure to the port of destination; this includes simple course change manoeuvres, speed adaptations etc. according to the voyage plan.

Manoeuvring in coastal areas, at entrances to ports and in harbour basins include manoeuvres, e.g. to embark and disembark a pilot, to pass fairways and channels and even berthing manoeuvres with or without tug assistance.

Manoeuvring in safety-critical and emergency situations deals with operational risk management and includes manoeuvres to avoid a collision or a grounding, to avoid dangerous rolling in heavy seas, or to manoeuvre in the case of an real accident e.g. return manoeuvres in case of a person overboard accident or when involved in Search-and-Rescue operations.

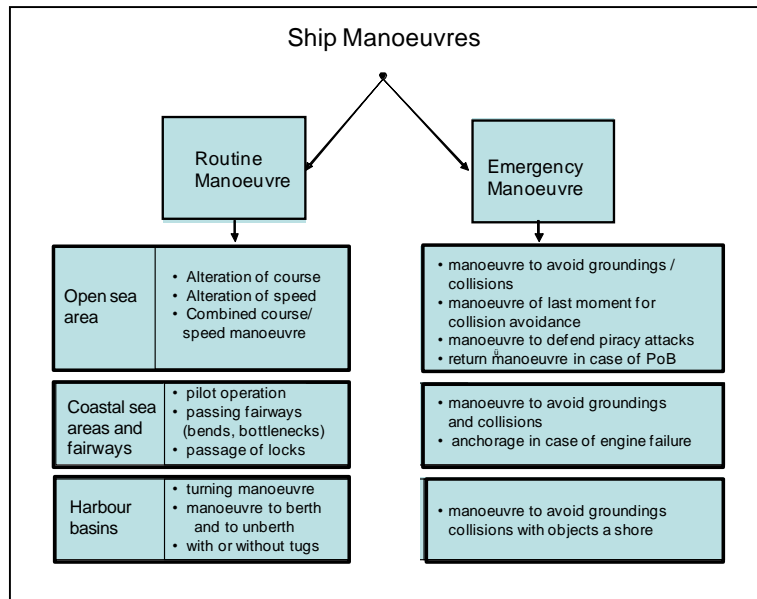

Figure 9: Systematization of ship manoeuvring

For each category specific manoeuvre use cases can be described. With respect to emergency manoeuvres in case of a person-over board, under varying conditions when it is urgently necessary to return to the location where a person was fallen over board, it can be concluded that there is a strong need to improve and support the ship command with more sophisticated situation-dependent manoeuvring information, especially in an emergency than it is provided by standard wheelhouse poster or manoeuvring booklet. It is worth to use the potentials of e-Navigation and apply dynamic predictions for the different phases of ship manoeuvring.

6.4 Manoeuvring process and simulation-based support

The manoeuvring process can be divided in four phases in principle:

1. Appearance of an event that requires a manoeuvre
2. Manoeuvre planning
3. Initiate manoeuvre execution
4. Monitoring with correcting action if needed

In the first phase a certain event causes the need for a change of the actual settings of a ship to alter her course and speed respectively. The responsible OOW then needs to plan a certain steering sequence (when to take what action in order to keep a certain track, that the navigator usually plans using his own mental model and imagine the reaction of the ship according to a rudder, engine or thrusters command.

When the ship is at the position to initiate keep the imaginary planned track the command will be executed. During manoeuvre execution the navigator checks the behaviour of the ship by comparing the actual ship status with his pre-planned imagination. In case he recognizes the need for correcting

actions those will be performed accordingly until the aim of the manoeuvre is reached and the ship is back in a constant moving status.

To support manoeuvring by dynamic predictions the expected track of a ship according to a certain manoeuvre is visualized preferably in an ECDIS-based display and on the one hand supports the imagination of the navigator and on the other hand provides an option to compare actual ship status and position with his planning.

Dynamic prediction can support all these phases of the manoeuvring process. This can be demonstrated at best in a environment of a desktop simulator or even better and preferably in a full-mission-simulation environment with the implemented technology.

A sample for such integrated processes is given in the following chapter explaining the use of dynamic prediction for planning berthing and execution of operation supported by applied software solutions.

6.5 Manoeuvring assistance using dynamic predictions

6.5.1 Dynamic prediction to support manoeuvre planning

In this chapter a case study of manoeuvring procedures in a harbour area is described to provide a sample for designing an integrated simulation exercise for training purposes. The exercise is part of the cooperation of WMU with German Institute of Innovative Ship Simulation and Maritime Systems (ISSIMS), who developed supporting software toolbox called SAMMON (Simulation Augmented Manoeuvring and Monitoring) providing dynamic predictions functionality on basis of innovative fast-time simulation methods integrated simulation environment of a full mission SHS. Fast time simulation (FTS) is a technology using a mathematical model of a certain process and its influencing factors to estimate the future status of a system faster than in real time. While real time simulation is e.g. especially used for training purposes the FTS is specifically used for operational tasks and to support decision making (Benedict & Kirchhoff et. al., 2014). For the purposes of ship navigation FTS can be used for the prediction of the ship's path taking into account the immediate reaction on control settings (rudder, thrusters, engine etc.). Differently to static predictions as e.g. the vectors in ARPA radar, dynamic path predictions are taking into account e.g. inertial forces and moments in relation to actual environmental conditions (wind, currents but also water depth etc.). The description of the case study is taken from [11] with minor amendments.

As an example for creating a berth plan and briefing the navigational officer an berthing scenario is chosen for an harbour area, the starting situation and the environmental conditions within this area on a sea chart is to be seen in the below figure. The objective is to berth the ship with Port Side at the Grasbrook Berth in the Hamburg Port area.

The respective harbour area is being divided into two manoeuvring sections, which are following a specific aim:

1. Section 1:

At the end of this section the SOG should be around 3 kn and the heading slightly towards southeast, being a preparation for section 2.

2. Section 2:

A state should be reached, where the ship can be held in the current at a position with constant heading and no speed. Then, the ship can then crab towards the berthing place mainly by means of thrusters. The current can be used therefore as an additional supporting aid to go alongside.

In a conventional briefing only these rough indications of the manoeuvring status can be used to develop a potential strategy for berthing the ship. The manoeuvres and setting of engine rudder and thrusters cannot be discussed in detail because no specific manoeuvring characteristics are available for the specific situations.

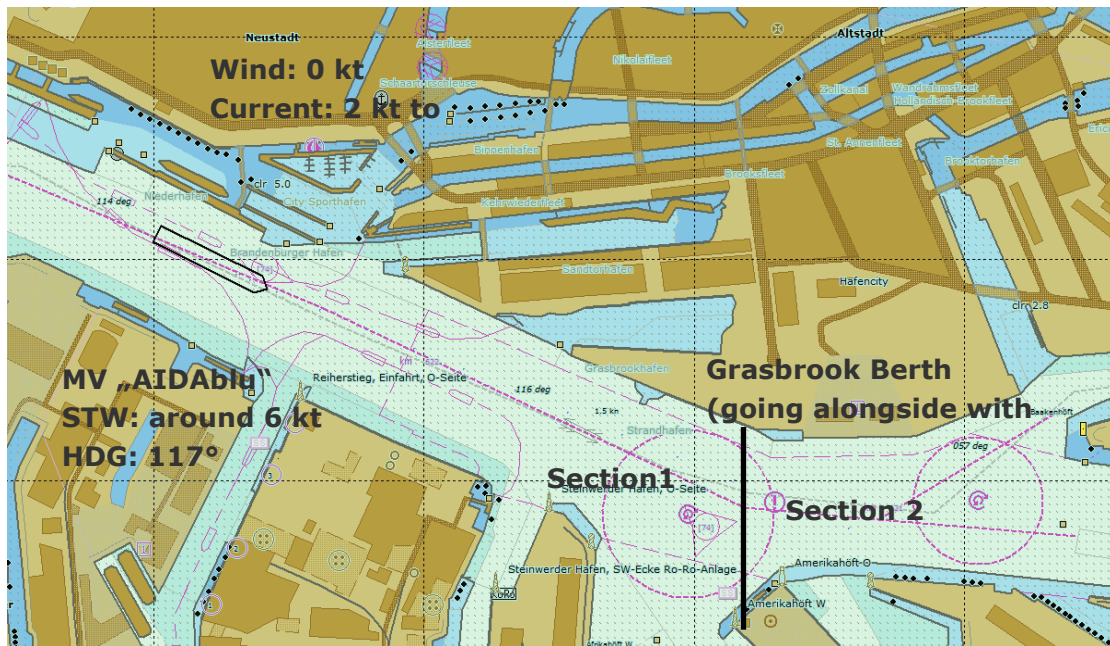

Figure 10: Exercise area and environmental conditions in Port of Hamburg for berthing scenario, divided into two sections for planning the manoeuvres

With the new fast time Simulation there is the chance for designing a Manoeuvre Plan as a detailed strategy with the specific settings at distinguished positions called the Manoeuvring Points MP. In the following the course of actions is described in a series of figures to make a full manoeuvring plan by means of the control actions at the manoeuvring points MP: In Figure 11 the initial position is to be seen where the instructor has set the ship in the centre of the fairway. The prediction already shows that the ship would drift slightly to port side due to the set handle positions. It can be learned that therefore the rudder has to be put slightly to starboard at the very beginning in order to follow the straight track until the next MP 1. At MP2 the rudder is set amidships again and both propulsion units are used to slow down and to steer the ship: the starboard engine is kept at 34 %, resp. 43 rpm to allow for a certain rudder effectiveness for steering control, whilst at MP3 the portside engine is set backwards in order to achieve about 3 kn SOG at the end of section 1.

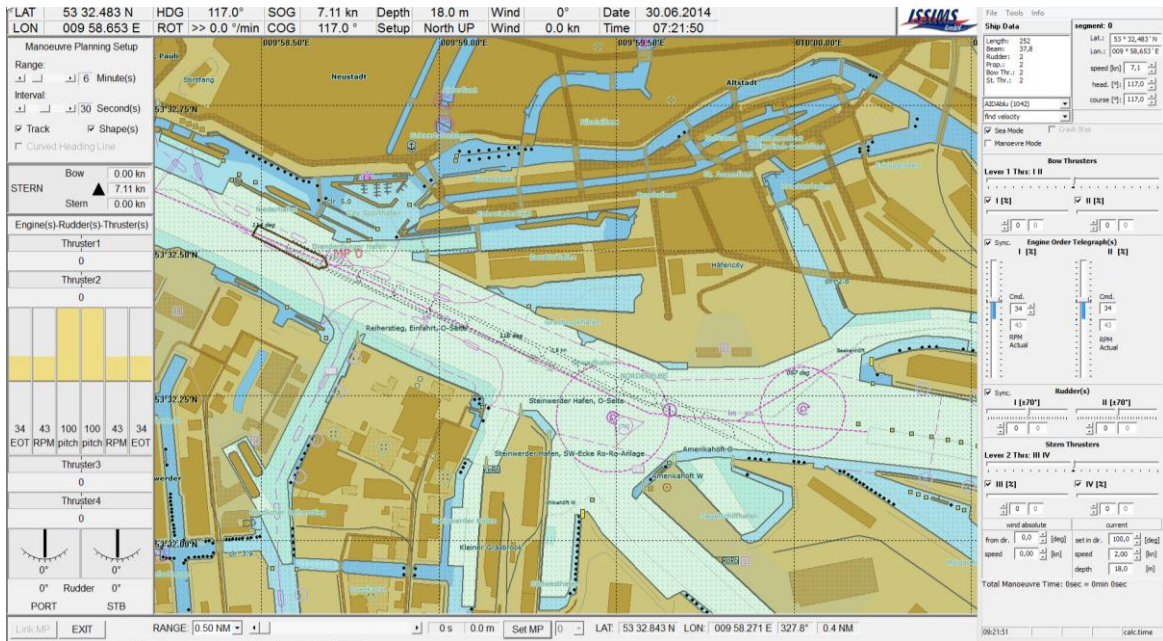

Figure 11: MP0: Initial position: The prediction already shows that the ship would drift slightly to portside due to the set handle positions.

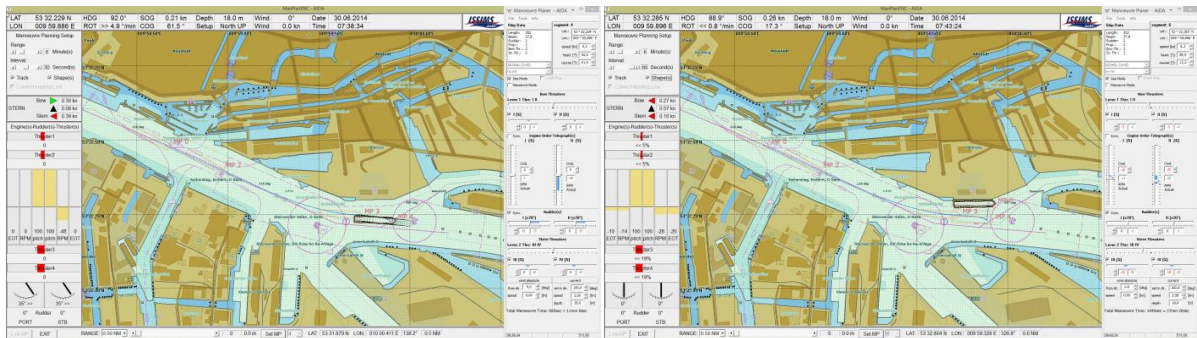

Figure 12: Final part of the manoeuvring plan: Left MP4 - The vessel is stopped and the heading is chosen in that way, that all handles can be set in zero position. Right: MP5 / MP6: the ship is already brought to the berth

In left Figure 12 the ship is stopped at MP4: The vessel's heading is chosen in that way, that all handles can be set in zero position, holding the ship with a minimum speed almost at the same position. At this moment, bow and stern thrusters can be applied to bring the ship safely to its berth. In the right figure the ship is already brought to the berth. The crabbing by means of bow and stern thrusters needs a further MP in order to reduce the transversal speed shortly before berthing.

The complete manoeuvring plan can be saved to be used for the training or to be loaded again for editing the plan for an optimisation to achieve a better performance for instance to do the whole manoeuvre in less time. For an in-depth discussion at the separate Manoeuvring Points and Sections there is the possibility to save the specific conditions as Situation files. These situation files can be useful for discussing strategies during the planning at different places where new challenges will come up as well as for the debriefing sessions. In Figure 12 at the right corner at the bottom the time

is to be seen for the complete series of segments: the Total Manoeuvre Time is about 17,5 minutes for this version of the plan. In Figure 13 some versions of the plan are to be seen with less time consuming manoeuvres. In the left figure it was tried to bring the ship to the berth without stopping before the final crabbing. Using the current as “supportive element” to bring the ship to the berth can be seen in the right figure.

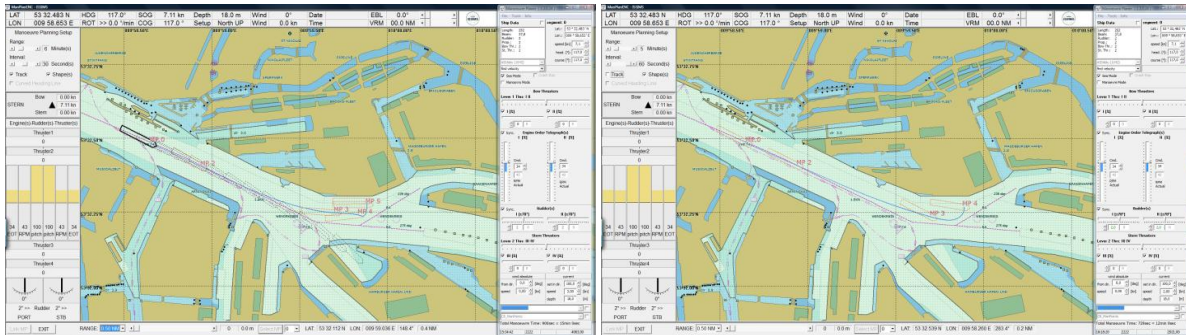

Figure 13: Alternative Manoeuvring plans – Left: with Total Manoeuvring Time 15 min more efficient because of immediate transfer to crabbing. Right: with Total Manoeuvring Time 12 min - Most efficient because of using the supportive effect of current for crabbing

6.5.2 Dynamic prediction to support manoeuvre execution

6.5.2.1 Berthing exercise according to conventional procedures

For comparing the effectiveness of the simulation augmented support tools a simulator test was made with trainees who have no support and trainees who have the full support. The result of this attempt by an experienced trainee who has no specific preparation for the exercise is seen for the ships track in Figure 14.

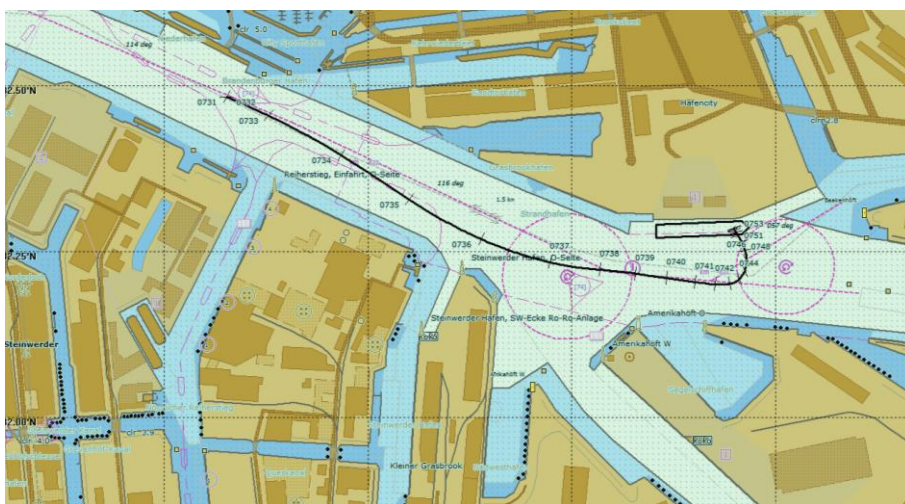

Figure 14: Result of manoeuvring training in ship handling simulator for a trainee with conventional preparation and no support by fast time simulation (Total Manoeuvring Time about 20 min)

The ship is set at the starting position and the task is to manoeuvre it to the berth with no Fast Time Simulation (FTS) aid at all. (Neither pre-planning by means of Fast Time Simulation nor manoeuvring prediction tools).

6.5.2.2 Berthing exercise using dynamic prediction support

During the exercise it is possible to take advantage from the Multiple Prediction for the manoeuvres. In Figure 15 the setup is to be seen where a student can bring his own laptop onto the simulator bridge (where he has already developed the manoeuvring plan), the prediction is controlled via the bridge handles.



Figure 15: Portable Setup for Prediction Display on ECDIS in Monitoring Tool on Students Laptop on a Full-Mission Bridge of a Ship handling Simulator– the prediction is controlled by the Bridge Handle. The dynamic prediction shows the future manoeuvring track whereas on the Radar Screen the static path prediction shows still a straight line according to the initial conditions of the ship

The same laptop with the Monitoring tool can also be placed at the instructor station. Alternatively the execution of an exercise can also be trained using the Trail & Training tool which is available on the same laptop for pre training see Figure 16. The ship's motion is then controlled via the same virtual handle panel on the screen as in the planning tool.

The principle layout of a prediction display integrated into an ECDIS is shown in Figure 16 in the Monitoring tool (which has no handle panel on the right side because the bridge handles are used). It

contains conning information together with the prediction and the planned manoeuvring track. The centre window shows the ENC together with motion parameter for longitudinal speed and transverse speed. The ships position is displayed in the centre of the ENC as ship's contour where also the track prediction can be indicated as curved track or as chain of contours for the selected prediction time. The prediction parameters as range or interval of presentation can be set in the control window at the left side.

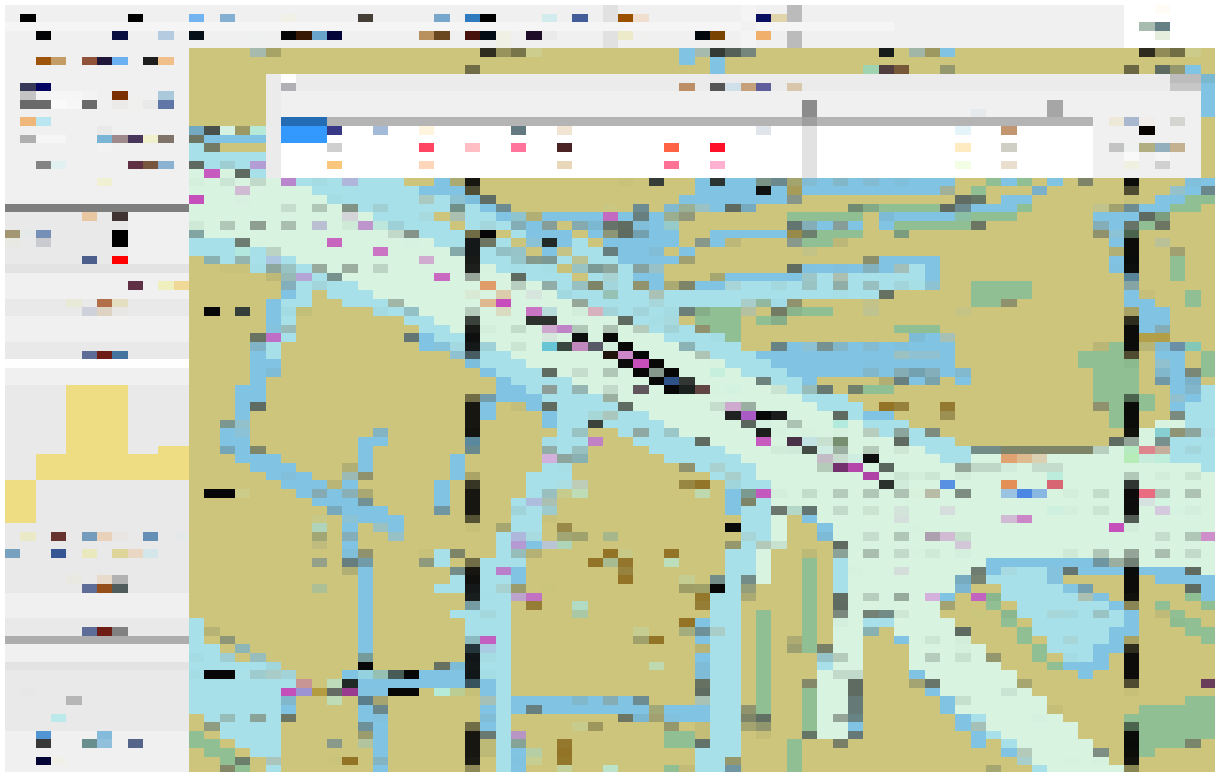

Figure 16: Layout for Manoeuvring Prediction integrated into ECDIS and comparison of full dynamic predictions (dotted ship contours) and the simple static prediction (magenta curve) together with planned manoeuvring track (blue line) in SAMMON Training Tool (same also in Monitoring Tool)

The following figure contains a comparison, made between the two simulator results of the trainees with different level of preparation and the manoeuvring plan of the second trainee. The achievements of the better prepared trainee are obvious – the planned manoeuvre is very close to the executed track and the actions of the controls has been done also nearly in accordance with the planned procedures.

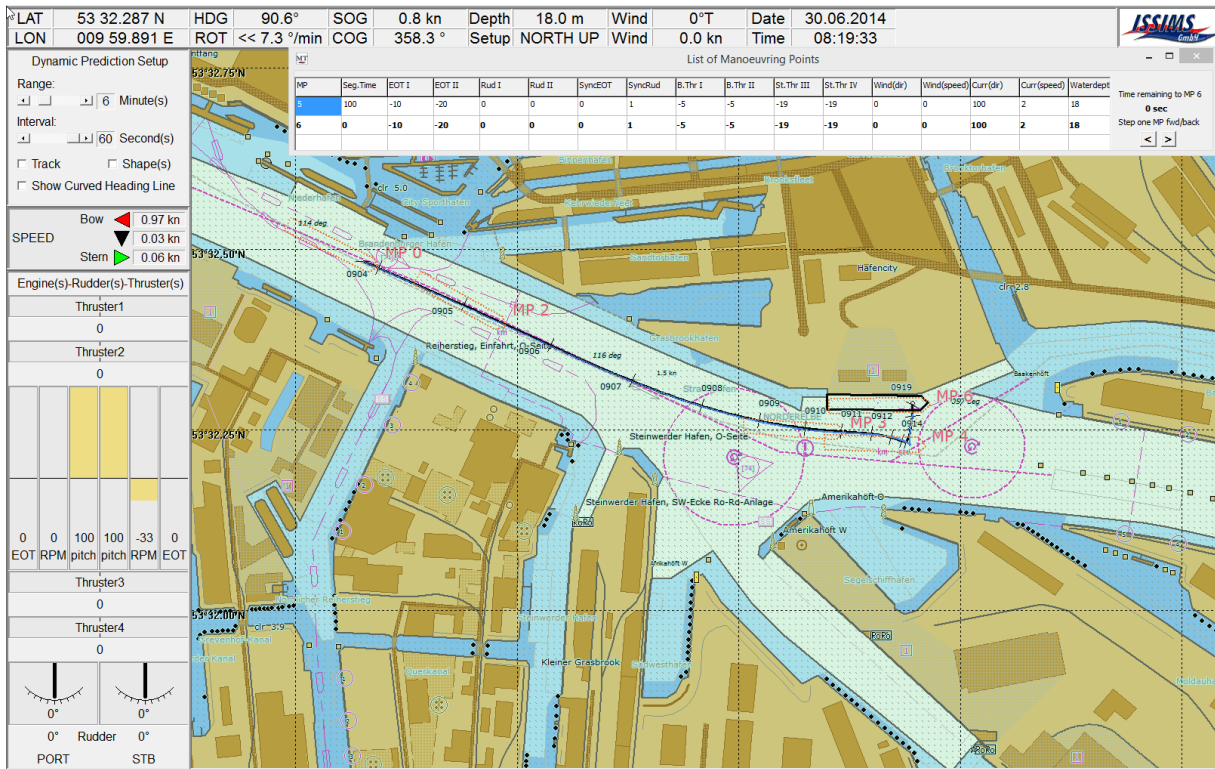

Figure 17: Result of manoeuvring for a trainee with advanced briefing preparation and full support by fast time simulation (Total Manoeuvring Time about 15.5 min)

It is obvious that there is not just a reduction of manoeuvring time when applying the Fast Time Simulation tool in briefing and training; the thruster diagrams show also that a well prepared manoeuvre can minimize the use of propulsion units and therefore be more efficient.

The benefit of using the FTS is to be seen for several purposes:

- The multiple dynamic predictions are always a great help for the navigator steering the ship: They obviously have a better overview on the current situation and the chances for the potential success of an action can immediately be seen; also for the co-navigator there is the chance to see both the manoeuvres and the success – this is a great situation because they can both share a better situation overview.
- multiple dynamic prediction may be used to see both the current state of motion by the static path prediction and the future development of the ship motion caused by the current handle settings – it is expected that the static prediction changes into the dynamically predicted track, in this case the prediction is correct. If not then the handle settings can be slightly adjusted to correct for the tendency of the potential impact of environmental effect which might not have been considered by the dynamic prediction, e.g. a non-detected current.

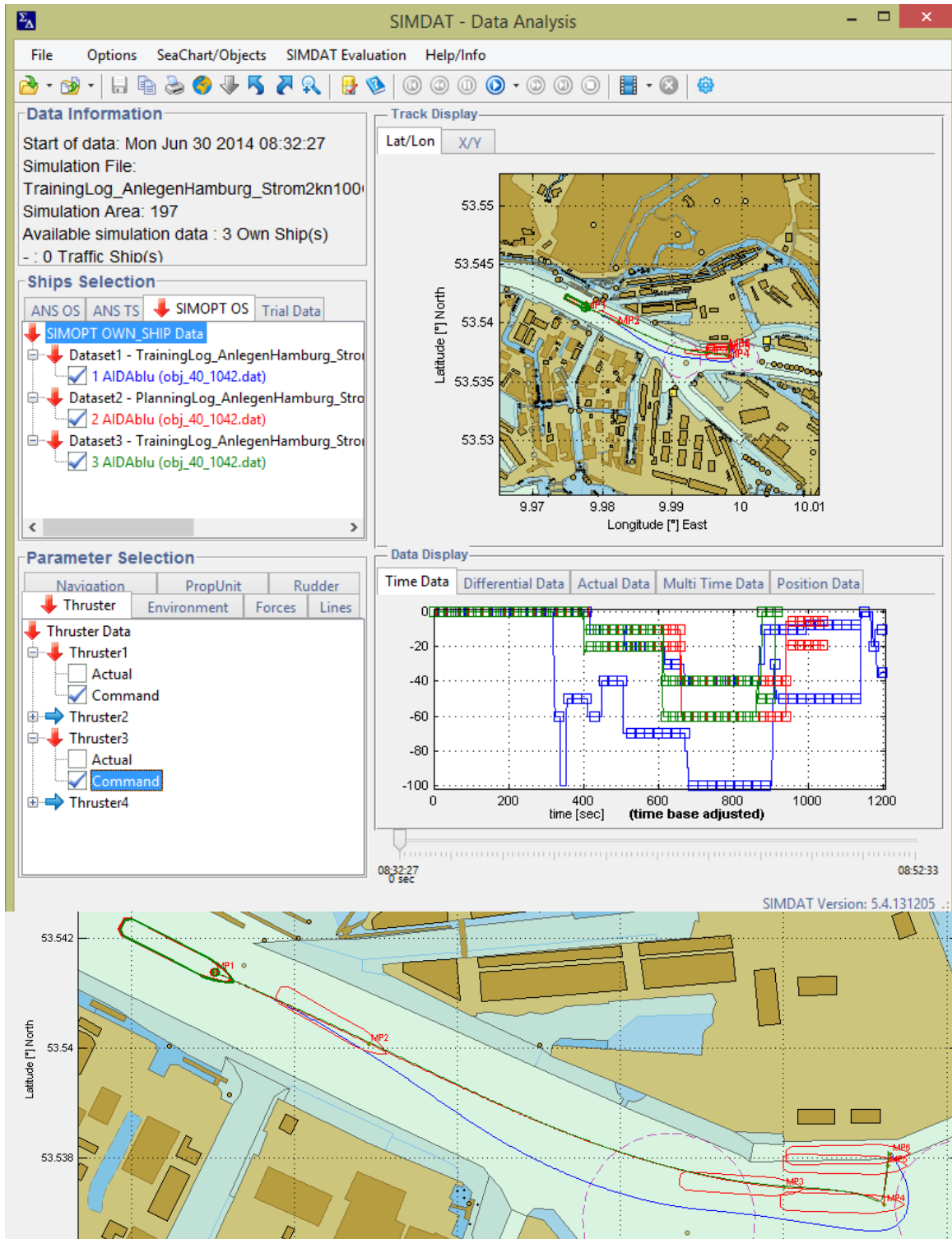

Figure 18: Results from two manoeuvring exercises in SIMDAT interface: “Track Display” with contours (Top and extract below) and „Data Display” for time history for thruster activities

- a) run of the trainee without support by Fast Time Simulation (blue)
- (b) run of the trainee with full support by pre-planning with Design and Planning Module (green)
- c) comparison to the prepared manoeuvring plan with manoeuvring points (red)

7 Conclusions and Recommendations

The primary task in the Training Needs Analysis was to explore and identify the training needs the ACCSEAS candidate solutions would generate in the on-board environment for the bridge team as well as ashore, for the VTS operators. The preceding chapters have elaborated on the multipronged research methodology adopted. Research interviews were conducted for the training needs analysis; simulation exercises were observed; focus group interviews were conducted in the debriefing sessions that followed; a questionnaire study was conducted and desk based research was conducted to study the courses already on offer.

The investigations performed in the frame of the ACCSEAS project are basing on the assumption that candidate solutions will be technically integrated into existing systems. Operational integration will take place in a way that the existing services provided today like INS, NAS or TOS will continue to exist but extended in their specific content in order to provide additional benefit for end users.

At the present state of technological development and operational integration of the suggested ACCSEAS candidate solutions the report concludes that no additional training in terms of an independent separate course is needed and to be foreseen.

The ambitions and aims of the development of the candidate solutions includes as easy and as simple handling and integration of new or advanced functions. Functions are developed in a way that the use of it shall be simply and intuitive to handle and as far as possible self explaining. These aims imply that training shall be minimized and can be focused on handling aspects. However, on the other hand so far the studied candidate solutions do not replace or substitute any existing training module of navigators, VTS operator or other end user.

All training with respect to the developed candidate solutions should ideally be integrated into existing training regimes such as the ECDIS. Training in ACCSEAS candidate solutions is required for the functionality/solution itself and the manner of its integration in on-board systems like the ECDIS. Training needs to include information and practice on how to use the functionality in the interface, navigation in the interface. The limitations and the caveats of the candidate solutions need to be integrated in the training to avoid overreliance. Training in intelligent filtering to avoid cluttering and information overload is considered essential. Computer Based Training (CBT) from the manufacturer providing training on the integration of the functionality, its use and limitations would be useful. CBT

should be further complemented by in-house training regimes of companies. Simulation training to immerse the trainees in scenarios highlighting the optimal utility of the candidate solutions is considered useful to add value to the training programme and to encourage the uptake of the developed solution.

With respect to the training needs of the VTS, the legal aspect of the candidate solutions like shore-based route suggestion, needed to be watertight. Appropriate terminology pertaining to the candidate solutions, in line with the legal aspect of the port authority needed to be identified and harmonised and included in the training for VTS operators. The VTS operators should be trained in procedures to incorporate the candidate solutions in their daily work, including the preparation of the bridge team to receive the solution such as the shore based route suggestion. The VTS operator training should further include content on considering the functionality as a supplement/additional tool to help them perform their work efficiently without any additional powers. Scenario-based simulation training was identified as particularly useful to bring the training experience closer to real life.

Thus far, a majority of the participants had undergone training standalone systems including type-specific equipment; however they have essentially not undertaken any training with respect to e-navigation in particular. The report concludes that training should provide a good understanding of the concept and as candidate solutions, functionalities and enhancements are developed, training should be made to include a variety of these new developments once they have been completed.

The results have revealed a lack of clarity regarding the concept of e-Navigation and there is no harmonisation in training for e-navigation and its functional applications. Harmonisation in policy, strategy, equipment and training need to be further worked towards to benefit from the novel candidate solutions developed under the ACCSEAS project.

Training needs with respect to the candidate solutions are best identified by conducting observations in a simulation environment followed by interviews. A high level of integration of the candidate solution in the simulation environment opens the mind of the users to accept the introduction of the novel solution into their working lives on-board and ashore, while on the other hand, a poorly integrated solution in an underdeveloped platform gives the wrong impression and creates a negative impression about the candidate solution and discourages uptake. Identification of training

needs, requires to move from simple to more complex solutions and accordingly the simulation scenarios would need to be more complex in the near future.

Further research and study activities needs to take into consideration the operational integration of newly developed or enhanced and advanced functions and services into existing regimes of a VTS or any future regime of providing enhanced e-navigation services to support bridge teams, pilots and other end users.

This page is deliberately blank.

8 References

- [1] The Interreg IVB North Sea Region Programme, Application Form 8th Call. **ACCessibility for Shipping, Efficiency, Advantages and Sustainability (ACCSEAS)**. Submitted 30 September 2011, approved by Grant Contract between Managing Authority of the North Sea Programme 2007-2013 represented by the Central Denmark Region and Trinity House (on behalf of the General Lighthouse Authorities of UK and Ireland) as Lead Beneficiary of the project, 28th June 2012, Journal-ID: 35-2-25-11.
- [2] ACCSEAS: *ACCSEAS Baseline and Priorities Report*, January 2015
- [3] IMO: International Convention on Standards of Training, Certification and Watchkeeping for Seafarers (STCW 2010), London 2010
- [4] IALA: Model Course V-103/1, Vessel Traffic Services Operator Training, Edition 2, Saint Germain en Laye, 2009
- [5] IMO: MSC 85/26/Add.1, annex 20, London, 2008
- [6] IMO: Sub-Committee on Navigation, Communications and Search and Rescue (NCSR), 1/INF.5, London, 2014
- [7] IMO: Sub-Committee on Navigation, Communications and Search and Rescue (NCSR), 1/9, London, 2014
- [8] Baldauf M., Benedict K., Krüger C. (2014): Potentials of e-Navigation – Enhanced Support for Collision Avoidance. *TransNav - the International Journal on Marine Navigation and Safety of Sea Transportation*, Vol. 8:4, 613-617
- [9] Procee, St. & Baldauf M. (2014) Augmented Reality in Ships Bridge Operation. in German Institute of Navigation (ed.): *ISIS 2014 – International Symposium Information on Ships*. pp. 190-200; ISSN 2191-8392
- [10] Benedict, K.; Gluch, M.; Kirchhoff, M.; Fischer, S.; Schaub, M.; Baldauf, M.; Müller, B. (2014) Use of Simulation Augmented Manoeuvring in Ship-Handling Simulator Training. in in Craig Dalton & Sam Teel (eds.): *18th International Navigation Simulator Lecturers Conference (INSLC18) Proceedings*, Plymouth Massachusetts, MMA Publishing, pp 46 - 59]
- [11] Benedict, K.; Gluch, M.; Kirchhoff, M.; Fischer, S.; Schaub, M.; Baldauf, M.; Krüger, C. M. (2014) Innovative Manoeuvring Support - from Today's Shipboard Organisational Structures to Shore Controlled Autonomous Ships. in Dev Ranmuthugala & Barrie Lewarn (eds.): *Looking Ahead - Innovation in Maritime Education Training & Research*. pp. 87-106, AMC, an Institute of University of Tasmania Local Executive Committee IAMU AGA15. ISBN 978-0-9806391-4-8
- [12] Baldauf, M. (2013) e-Navigation and Training. *Maritime Reporter and Engineering News*, John O'Malley's Publisher., New York, November 2013 pp. 64-69
- [13] Baldauf, M. (2013) e-Navigation a key for safe, efficient and sustainable shipping. *Baltic Rim Economies Quarterly Review*, Special Issue on the Maritime Sector Developments in Global Context, Issue No. 6, pp. 9-10, Turku November 2013
- [14] Holder, E.; Motz, F.; Horoufchin, H.; Baldauf, M. (2014) Concept for the Integration of Information Received Via Communication Equipment with Onboard Navigational Systems. in: Neville Stanton, Giuseppe Di Bucchianico, Andrea Vallicelli, Steven Landry (eds.): *Advances in Human Aspects of Transportation: Part I*, pp. 203-215, AHFE Conference 2014, ISBN 978-1-4951-2097-8

- [15] Baldauf, M.; Benedict, K.; Gluch, M. (2014) *Ensuring safety and efficiency by e-Navigation related traffic surveillance*. Port & Technology International, Henley Media Group, London, 47(2) November 2014 pp. 98-103
- [16] Baldauf, M. (2014) *Set a new course for e-Navigation*. Nautilus International Telegraph, Redactive Media Group, London, 47(2) February 2014 p. 27-28

9 Appendices

9.1 Appendix 1: Semi structured qualitative interview tool for instructors

- 1) Please give a presentation of yourself and your profession!
- 2) Please give a presentation of your MET!
- 3) What do you know about e-Navigation?
 - For how long time has you taught in e-Navigation?
 - What is your own professional experience at sea in this subject?
- 4) Does your MET offer e-Navigation?
 - For how long time has your MET offer e-Navigation?
 - How do you intend to implement e-Navigation related issues, subjects into your existing training schemes?
 - What is the specific content, (topics, subjects) that you have included (or you intend to include) into such a course?
 - Can you explain how the e-Navigation courses are performed?
 - Is it possible to send the course-plan?
 - What are the main challenges of the introduction and application of the e-Navigation concept with respect to MET?
 - What do you think? What kind of equipment (hardware/software) is necessary to establish and provide e-Navigation seminar in your training-centre or university?
 - Have you seen or are aware of gaps regarding the education and training in e-Navigation? (Examples?)
 - Have you been approached, asked by any company, organisation, institution or any of your 'clients' regarding courses dealing with e-Navigation training?
 - Do you think e-Navigation to be a potential solution (or rather a contribution to) to attract young people to become mariners?
- 5) Having in mind IMO/IALA's e-Navigation concept -Do you think there is a need for a specific training subject "e-Navigation"?
 - What items, topics should be included?

- What, from your point of view, would be a reasonable amount of time for such a subject "e-Navigation".

6) Something else you want to add?

9.2 Appendix 2: Policies

- DEFINITION of e-Navigation; clarification, IMO, IALA, IHO
- DATAPROTOCOL
 - AUTOMATION OF INFORMATION SHIP-ASHORE
 - VTS
- DOCUMENTED SKILLS; e-Certificate, Requests by inspectors of a new type of document of e-training
- FEW REGULATIONS; e-navigation formed by free development
- HARMONIZING THE EQUIPMENT ON BRIDGE;
- IMO; Feed-back, Communication in advance because of planning
 - STCW; Output
 - CIRCULATIONS; Problems, without demonstrations
- MINIMUM LEVEL; content in e-Navigation
 - MODEL-COURSE; main-aspects in training
 - LACK OF FORMALIZING; dependent of interest
- PORT REPORTING; standardization
- ROUTE-PLANNING;
- PERFORMANCE; - standardization necessary
 - Performance of e-Navigation; content, how, why, when, etc.
 - WITHOUT e-Navigation - to manage situation
- POLICIES; regulations of training activities, directly and indirectly
- POLICIES; not to use installed equipment by shipping companies
- SCHOOL-STRUCTURE; domestic maritime system
 - Equipment, Simulators, Laboratory, Teachers,

EQUIPMENT

- SIMULATORS; Equipment content, Integration, Functionality, Engine, Stream, Vessel-Vessel-Ashore, etc.
 - DESKTOP SIMULATORS; Presentation, Route-planning
 - TECHNOLOGY VS. PAPER
 - UPDATE OF SIMULATOR; software
- IHO; Weather-communicates in-cooperated
 - ECONOMY; Saving of fuel
 - ENVIRONMENT;
- ECDIS; Chart

- CHART; interface
- COST, equipment, hardware and software
- END OF DEVELOPMENT, time-frame
- MANUFACTOR APPROACH; all directions
 - RADIO; Communication
 - TRANSAS VS. KONGSBERG; Vessel,
 - SCHOOLS NEGOTIATION, manufactures
 - AIS & VTS
- MANUFACTORS RESTRICTIONS; software, global differences
 - BACKUP; software, processing, automatic,
- MAINTENANCE; spare parts, function - global permission,
- REVALIDATEING; updates of software vs. model-course, IBS & INS
- STANDARD-BUTTON; interface, individual/fixed
 - ACCESS; password, transmission
 - MONITOR; Night-mode-awareness
- UPDATE OF SOFTWARE; automatically/managed central/not vessel - no delay in running

HUMAN

- ACCESS TO e-NAVIGATION TRAINING
- COMMUNICATION; vessel-vessel-ashore
- LEARNERS' prior experiences and future work content
- LEARNERS' ATTITUDE; change their mind;
- TEACHERS' QUALIFICATIONS
- HF-TRAINING; BRM, CRM, Emergency, group-interaction,
 - FAILURE; stress coping

TRAINING

- ADVANTAGES VS. DISADVANTAGES OF e-Navigation
- COST; huge effect on training
- HAND-OVER OF BRIDGE-SCREENS,
- LANGUAGE; Translation
- PORT SERVICES;
- REPORTING AND INFORMATION EXCHANGE;
- SHORT TIME PORT; charge/discharge
- TERMINOLOGY
- TIME OF TRAINING; gap in opinion, content; 1w-1days/daily profession, vessel, culture

- TRAINING ONBOARD; on-going
 - TRACK-HOLDING BY THE COMPANY; Training frequencies
 - VISUAL-CHECKS;

COMPETENCES

- DEFINITION of e-Navigation; clarification
- COMPETENCE; teachers & learners of e-Navigation
 - SEA EXPERIENCE; Based ashore
 - REFLECTION OF GAPS; Awareness
 - E-NAVIGATION CERTIFICATE; range
- COMPUTER-KNOWLEDGE-SKILLS;
 - OLD/YOUNG; Old skilled in basic knowledge subject vs.
Young skilled in typing on the computer without-inferior knowledge
 - INTERFACE;

9.3 Appendix 3: Guiding questions for ACCSEAS interviews with mariners

- Introduction about the ACCSEAS project.
 - Participant consent for recording of interview
1. Biographical questions including
 1. Background (Name, rank, age etc.)
 2. Number of years at sea (Type of ship/ service)
 2. Are you aware of the concept of e-navigation?
 1. If Yes – (What is it?)
 1. Could you please elaborate on your understanding of e-navigation (What e-navigation means to you?).
 2. Which training institute/ where have you obtained your licence from?
 3. What training have you undergone? (type)
 4. Have you undergone any internal training courses?
 5. What is the training situation in your home country?
 6. Have you received any specific training for e-navigation?
 7. Are you satisfied with the training you have received on e-navigation?
 8. What are your expectations from specific training besides celestial, radio, terrestrial navigation?
 2. If No – Define the concept, ask question below and thereafter ask Q number 5 & 8 from above and continue below to questions pertaining to applications of e-navigation and expectations from training course).
 1. What is your feeling about the concept of e-navigation? (what is your take on it/ how do you react to it)
 3. What are the applications of e navigation in your work?
 4. What could be the potential applications of e-navigation according to you?
 1. What information do you require from other parties (ships, VTS etc.)
 2. What information you would like to share with other entities?
 3. How would you like this shared information presented?
 4. Views on diverse un-integrated shipboard equipment
 5. Views on aspects like CPA and its variability in diverse conditions and whether it is acceptable/ comfortable to take the CPA from the VTS
 6. What is your wish/opinion that technology should deliver in terms of seamless integration between the ship and the shore and contribute to enhanced safety?
 7. What are your expectations from e-navigation?
 5. E navigation training questions
 1. Do you expect that it might become a subject for inclusion into the STCW?
 2. Should there be an IMO model course on the subject?
 3. What should be the content of the course on e-navigation?
 4. What would you like to know in the course? (learn from the course)

5. What are your expectations from the e-navigation training course?
6. What should be the timing of such course in the training scheme?
7. Opinions on re-familiarisation training on-board different ships with different manufactured equipment.

9.4 Appendix 4: Training provision, UK



Maritime &
Coastguard
Agency

ECDIS - MCA Approved Training Providers

Training Providers: If you are an approved MCA course provider and not on this list or if your details need updating please email: stc.courses@mcga.gov.uk . If you hold pilot approval you will need to wait until full approval is granted by an MCA surveyor before being listed below.

Seafarers: If you have undertaken or are about to undertake MCA approved training and it is not listed below, please email exams@mcga.co.uk to ensure it is MCA approved.

UK Approved Training Providers

Company	Location	Address	Contact Details	Website
Blackpool and Fylde College	Fleet wood, Lancashire	Fleetwood Nautical Campus, Broadwater, Fleetwood, Lancashire, FY7 8JZ	Tel: 01253 779123 Email: maritime@blackpool.ac.uk	www.blackpool.ac.uk/nautical
City of Glasgow College	Glasgow, Scotland	21 Thistle Street, Glasgow, G5 9XB	Tel: 0141 565 2500 Email: maritime@gcns.ac.uk	www.cityofglasgowcollege.ac.uk
ECDIS Ltd	Fareham, Hampshire	Atlantic 3600, Parkway, Solent, Whiteley, Fareham, NE34 6ET	Tel: 07795383306 Email: broster@ecdis.org.uk	www.ecdis.org
Lairdside Maritime Centre	Campbeltown, Wirral	3 Vanguard Way, Campbeltown, Wirral, CH41 9HX	Tel: 0151 647 0494 Email: lairdside@livim.ac.uk	www.lairdside-maritime.com
Lowestoft College	Lowestoft, Suffolk	Maritime and St Peter's Street, Lowestoft, NR32 2NB	Tel: 01502 583521 Email: maritime@lowestoft.ac.uk	www.lowestoft.ac.uk/maritime.asp
Maersk Training Newcastle Ltd.	North Shields, Northumbria	Unit 11 & 12, Orion Business, Tyne Tunnel NE29 7SE	Tel: 0191 2703220 Email: newcastle@maersktraining.com	www.maersktraining.com
NAFC Marine Centre	Shetland, Scotland	Port Arthur, Scalloway, Shetland, ZE1 OUN	Tel: (01595) 772000 Email: nainfo@uhi.ac.uk	www.nafc.ac.uk
Northern Marine Manning Services	Glasgow, Scotland	Alba house, 2 Central Avenue, Clydebank, Glasgow, G81 2QR	Tel: 0141 8763000 Email: enquiries@nmms.co.uk	www.nmms.co.uk
Red Ensign Limited	Cowes, IOW	105 Medina Village, Medina Road, Cowes, Isle of Wight PO31 7LP	Tel: 01983 294088 Email: info@quality-time.info	www.redensigntraining.com
Scottish Maritime Academy	Aberdeenshire, Scoland	South Road, Peterhead, Aberdeenshire, AB42 2UP	T +44 (0)1779 476204E sma@nescol.ac.uk	www.smaritime.co.uk
South Tyneside College	South Shields, Northumbria	St George's Avenue, South Shields, Tyne & Wear, NE34 6ET	Tel: 0191 427 3772 Email: marine@stc.ac.uk	www.stc.ac.uk/content/marine-college/courses
UK Sailing Academy	Cowes, Isle of Wight	Arctic Road, West Cowes , Isle Of Wight , PO31 7PQ	Tel: 01983 294941 Email: mavis.barry@uksa.org	www.uksa.org
University of Plymouth	Plymouth, Devon	Diving and Marine, Artillery Place, Plymouth, PL4 0LU	Tel: 01752672783 Email: divingcentre@plymouth.ac.uk	www.plymouth.ac.uk
Warsash Maritime College	Southampton, Hampshire	Newtown Rd, Warsash, Southampton, SO31 9ZL	Tel: 023 8201 5004 Email: wma.training@solent.ac.uk	www.warsashacademy.co.uk
Western Training Association	Plymouth, Devon	Units 1 and 2, Crown Hill Fort, Plymouth, Devon, PL6 5BX	Tel: 01752 770589 Email: enquiries@swta.co.uk	www.swta.co.uk

9.5 Appendix 5: Questionnaire study online tool

Available as a PDF file on request

Appendix 6:

**Use of Simulators in e-Navigation Training and Demonstration.
(WMU Input Paper to ACCSEAS Simulator working group)**

Available as a PDF file on request