



NORTH SEA REGION ELECTRIC MOBILITY NETWORK

e-mobility **NSR**

# Standardization of EV Recharging Infrastructures

Report written within the framework of Activity 4.4  
of the Interreg IVB project E-Mobility NSR

**Sjoerd Bakker | December 2013 | Delft**

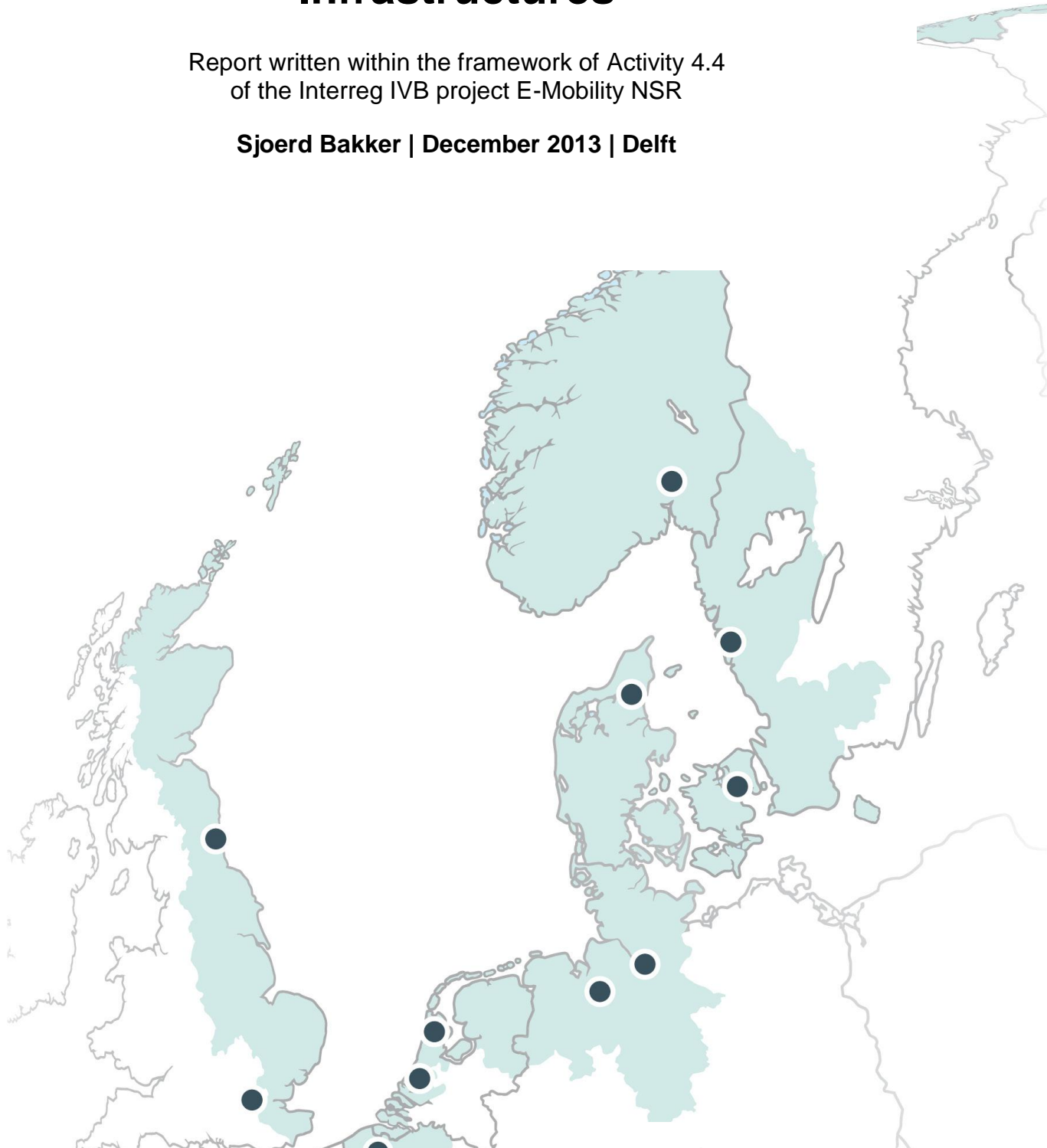



# Contents

|  |           |
|--|-----------|
| <b>1. Introduction .....</b>   | <b>4</b>  |
| <b>2. Electric vehicle recharging standards.....</b>                   | <b>6</b>  |
| 2.1 Specific standards: modes, types, and identification systems ..... | 7         |
| <b>3. A History of Electric Vehicle Recharging Plugs .....</b>         | <b>10</b> |
| 3.1 AC Charging.....   | 10        |
| 3.2 DC Charging.....   | 13        |
| <b>4. Plugs in use in the NSR region .....</b>                         | <b>16</b> |
| 4.1 United Kingdom.....  | 16        |
| 4.2 Belgium .....  | 17        |
| 4.3 The Netherlands.....   | 17        |
| 4.4 Germany.....   | 18        |
| 4.5 Denmark.....   | 18        |
| 4.6 Sweden .....   | 19        |
| 4.7 Norway .....   | 19        |
| <b>5. Initiatives to realize international interoperability .....</b>  | <b>20</b> |
| 5.1 Ladenetz.....  | 20        |
| 5.2 Hubject .....  | 20        |
| 5.3 Crome.....   | 20        |
| 5.4 Green eMotion.....   | 21        |
| <b>6. Conclusions: looking forward.....</b>                            | <b>22</b> |

# 1. Introduction

Electric vehicles of various manufacturers are being deployed throughout Europe. To recharge these vehicles, an infrastructure of rechargers is needed to enable charging at both private and public parking facilities. Throughout the world and also within Europe, different charging protocols, plug designs and billing systems have been developed and introduced. In fact, even within many (European) countries, various networks with proprietary identification and billing systems have emerged that do not (yet) allow EV drivers to roam between these networks. The variety and incompatibility among these networks makes that EV drivers can't use their EVs to their full potential and that cross-border trips are virtually impossible. Besides the practical value of interoperability to EV drivers throughout Europe, one could also argue that standardization would be beneficial to equipment manufacturers and charging network operators as it would provide much needed clarity and bring about positive scale effects. Furthermore, standardization could also take away some of the uncertainties among potential EV-drivers and, in a broader rhetorical sense, position the EV as a viable option today instead of presenting it as an underdeveloped future option.

The EU has more than once called for standardization of EV charging systems, but only recently a clear directive was published that provides clarity on the charging systems and plug designs that are to become the new European standard. Harmonization of the connecting hardware is however only a first step towards true interoperability of European charging networks and much needs to be done to ensure that EV drivers can actually charging their cars anywhere in the EU. This report aims to provide an overview of available standards, the process of standardization, and the actual use of the different standards in the different NSR countries and regions. It does however not describe the technical aspects of the standards in full technical detail, nor does it prescribe which standards are to be preferred or which standards should be installed<sup>1</sup>. In short, this report covers three aspects of the standardization of charging networks:

- a **short history** of various plug designs and the regional standards that have emerged
- an **overview of the various systems that are in use** in the seven North Sea Region (NSR) countries
- an overview of **efforts to enable interoperability** in the EU, with a focus on the NSR countries.

This report is based on three empirical foundations. First, online news sources were mined for announcements about charging standards<sup>2</sup>. Second, several reports and publications about charging standards and billing systems were consulted. Third, interviews were held with numerous stakeholders in the seven NSR countries as part of a broader stakeholder analysis concerning the realization of (public) charging networks.

Within the framework of the E-Mobility NSR project, this report relates to the following other studies. These studies are available for download at: <http://e-mobility-nsr.eu/info-pool/>

- **Stakeholder strategies regarding the realization of an electric vehicle recharging infrastructure**

---

<sup>1</sup> Technical details of the various standards can be found, amongst others, in publications from the Green eMotion project: <http://www.greenemotion-project.eu>

<sup>2</sup> This part of the study was carried out by an intern at TU Delft, Pieter Leguijt

Describes the development of recharging infrastructures in the countries and thereby concentrates on the task division between various stakeholders. Thereby this report provides an overview of business models for both regular and fast chargers and an overview of ways in which national and local government has supported the infrastructure build-up. Interview data for both reports was gathered in the same series of interviews and thus from the same respondents.

- **Electric vehicle charge point map websites in the North Sea Region**

An overview and assessment of the various charge point websites. These websites are potentially powerful tools to monitor the standardization process in the respective countries. They were used for this report in a qualitative manner, and may also be used to quantify degrees of standardization, provided that they are truly reliable and provide full coverage of actual charging stations.

- **Electric mobility policies in the North Sea Region countries**

An overview of supportive policies for both vehicle adoption as well as infrastructure build-up

- **Danish Experiences in Setting up Charging Infrastructure for Electric Vehicles with a Special Focus on Battery Swap Stations**

A detailed description of developments Denmark concerning the realization of the Danish infrastructure, with a focus on Better Place's swapping stations.

- **Micro to Macro Investigation**

A detailed description of the British Plugged-in-Places initiative with a focus on the role of public stakeholders.

## 2. Electric vehicle recharging standards

There are three basic options for recharging an electric vehicle: wired, wireless by means of induction<sup>3</sup>, and by swapping its batteries<sup>4</sup>. The remainder of this report deals exclusively with wired charging since this is currently the only option that is used in practice and for which both cars and charging equipment are commercially available.

For wired charging, two options can be distinguished: AC- and DC-charging. Charging with **alternating current (AC)** is used for conventional and semi-fast charging at homes and offices and the majority of public recharging stations. **Direct current (DC)** is used for fast charging. Since all batteries require DC power to be charged, the AC power that is delivered by the electricity grid needs to be converted to DC at some point. An AC/DC converter is thus needed between the grid and the battery. In the case of AC charging with regular mains power, power levels are low enough to install a small converter on-board the vehicle. For fast charging with higher power levels, a bigger and more expensive converter is needed that would not easily fit in a typical car. These high-power converters are therefore incorporated in the charging station and DC power is delivered to the car (See Figure 1 for a schematic drawing of these differences). Also, because of the higher power levels and related safety concerns, DC charging cables are always fixed to the charging station and there is thus only one plug that needs to be standardized. AC charging cables are often, but not always, loose cables with plugs on both ends and standardization may thus be necessary for both plugs. In the following sections we will present and discuss the emergence of the various AC and DC standards separately and also address the need for standardization on the car- and wall-side.

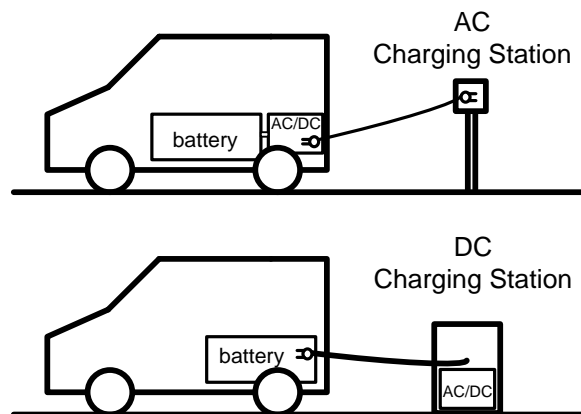

3 A battery can be charged inductively without using cables. Instead, an electromagnetic field is used to transfer energy to the vehicle. This way of charging is tested in numerous experiments and may very well become the charging mode of the future. Today however, no cars are ready for conductive charging nor are there any standard chargers available for this. Still, it is an attractive option because it does not involve any cumbersome equipment or cables and thereby does not spoil the streetscape in inner cities for instance. Also, and perhaps more importantly, it could be used for charging while driving by means of inductive road surfaces or for instance to quick-charge buses at bus stops.

4 An empty battery can be swapped with a fully charged one. Potentially this is the fastest way of “recharging” an EV, but most likely also the most expensive way since it requires the construction of (automated) swapping stations. Additional batteries are needed as well. Furthermore, standardization of EV batteries would be needed to some extent (to prevent stocking a wide variety of battery types and sizes), and EVs need to be specifically designed to be suitable for battery swapping (most of them currently are not). The company Better Place was well known for developing and deploying swapping stations in, amongst others, Israel, Denmark, Japan, and the Netherlands, but went bankrupt in May 2013. Renault was the only car manufacturer that cooperated with Better Place and has produced about a thousand Fluences with switchable batteries. The dedicated EV manufacturer Tesla Motors has also announced that it is testing battery swapping options, but this has not been done outside its factory gates yet (<http://www.teslamotors.com/batteryswap>).

Figure 1 Schematic drawing of AC and DC charging stations.

## 2.1 Specific standards: modes, types, and identification systems

For both AC and DC charging, multiple plug designs and charging modes have been developed and have been deployed throughout the world. Next to that, an even wider variety of identification and billing systems have been developed. In order to enable EV drivers to roam between networks and ultimately between countries, interoperability, and thus standardization, is necessary between the various modes, plugs, and identification and billing systems. Below we introduce these concepts and explain the major differences between the various options.

### 2.1.1 The charging mode:

The charging mode refers to power levels that charger and its connectors are rated for and the control and safety features that guarantee safe and efficient charging. The International Electrotechnical Commission (IEC) has recognized four different charging modes that vary in terms of complexity of the system and the speed with which a vehicle can be recharged.

**Mode 1** charging encompasses charging from regular mains sockets (up to 16 Amperes) and is done without any specific safety or communication features. This mode by definition requires the usage of a loose cable with plugs that match the car-side as well as the wall-side (e.g. a home socket or charging equipment).

**Mode 2** charging encompasses charging from regular mains sockets as well, but features a special cable with a so-called in-cable-control-box that controls the power level and thereby protects the user and the vehicle. Both Modes 1 and 2 are used in situations where a dedicated infrastructure is lacking (e.g. at home) or where the network operator has decided to offer a rather uncomplicated system. For instance, in Norway, most of the ‘regular’ recharging network consists of basic sockets that can be used by any EV-driver who has a key to unlock the charger. Because Mode 1 and 2 charging make use of regular sockets, plug designs vary per country and cross-border trips would require the use of several cables with varying plugs on the wall-side.

**Mode 3** charging, which is to become the European standard, makes use of dedicated charging equipment which guarantees safe usage and which also enables communication between the charging equipment and the vehicle. Because of these additional features, a special cable and plug and socket combination are necessary.

Finally, **Mode 4** charging entails the use of an AC/DC converter and charger in the charging equipment (instead of on-board the vehicle) and DC power is delivered to the vehicle. Mode 4 is typically used for fast charging with power levels starting at 50 kW

### 2.1.2 The plug type

The plug type refers to the physical design of the plug(s) with which the vehicle is connected to the charging equipment. There are three officially recognized plug designs for Mode 3 charging, these are designated as Types 1, 2, and 3.

**Type 1** (Yazaki) is used mainly in the U.S. and Japan and is supposed to be used on a cable that is fixed to the charging equipment. In other words, the Type 1 plug is used specifically to plug into the car and therefore requires a car with a compatible inlet (the vehicle inlet).

The **Type 2** plug (Mennekes), the new European standard, is used on loose cables and connects the cable to the charging equipment. On the car side, the cable can have any plug that matches the vehicle’s inlet, but this often a Type 1 design because many cars have a Type 1 inlet anyway. Type 2 plugs are rated for higher power levels than Type 1 plugs and can therefore be used for semi-fast charging with chargers that make use of three-phase power connections.

The **Type 3** plug (Scame) is mostly the same as the Type 2 plug, but its use is limited to several countries in southern Europe (i.e. Italy, France). These countries prescribe the use of so-called safety shutters on power outlets that are installed outside and the Type 3 socket features such shutters. Because the Type 2 and 3 plug and socket combinations are not compatible, travelling between, for instance, Germany and France would require an additional cable.

As for mode 4, DC fast charging, there is currently only one design that is used in practice. This is the **CHAdEMO** standard and this standard specifies the charging protocol as well as the physical design of the plug and vehicle inlet. This implies that a CHAdEMO charger, like all mode 4 chargers, makes use of a fixed cable. As will be described further on in this report, a large consortium of car manufacturers has agreed on a competing standard in which either a Type 1 or Type 2 plug is combined with additional pins for DC power. These are the **Combo 1 and 2** plugs and are meant to be used on vehicles with a matching vehicle inlet that is also compatible with Type 1 and Type 2 plugs.

No actual standardization has taken place yet in Europe and the various plug types are still in use and most countries have in fact not even agreed on a national standard, despite an announcement from the European Commission in January 2012<sup>5</sup>. In this (proposed) directive two plug designs are selected to become the EU standard (Type 2 and Combo 2). To quote the report:

- *Alternate Current (AC) slow recharging points for electric vehicles shall be equipped, for interoperability purposes, with connectors of **Type 2** as described in standard EN62196-2:2012.*
- *Alternate Current (AC) fast recharging points for electric vehicles shall be equipped, for interoperability purposes, with connectors of **Type 2** as described in standard EN62196-2:2012.*
- *Direct Current (DC) fast recharging points for electric vehicles shall be equipped, for interoperability purposes, with connectors of **Type "Combo 2"** as described in the relevant EN standard, to be adopted by 2014.*

**Table 1 Plug types and maximum current and voltage levels, based on Van den Bossche 2010<sup>6</sup> and SAE<sup>7</sup>, GreenEmotion<sup>8</sup>**

|                      | Current (A)     | Voltage (V) | Power (kW) | Charging Point            | Vehicle                         |
|----------------------|-----------------|-------------|------------|---------------------------|---------------------------------|
| <b>Type 1</b>        | 32              | 250         | 7.2        | Cable with plug           | Standard inlet today            |
| <b>Type 2</b>        | 63 <sup>9</sup> | 480         | 44         | Cable with plug or socket | Announced by consortium of OEMs |
| <b>Type 3</b>        | 63              | 480         | 44         | Socket                    | N/A                             |
| <b>CHAdEMO</b>       | 125             | 500         | 62.5       | Cable with plug           | Standard inlet today            |
| <b>Combo 1&amp;2</b> | 200             | 500         | 100        | Cable with plug           | Announced by consortium of OEMs |

<sup>5</sup> Proposal for a DIRECTIVE OF THE EUROPEAN PARLIAMENT AND OF THE COUNCIL on the deployment of alternative fuels infrastructure

<sup>6</sup> Van den Bossche, P. (2010). "Electric Vehicle Charging Infrastructure" Chap. 20, In: Electric and Hybrid Vehicles - Power Sources, Models, Sustainability, Infrastructure and the Market, edited by G. Pistoia, pp. 517-543. Amsterdam: Elsevier.

<sup>7</sup> <http://www.sae.org/mags/aei/11005/>

<sup>8</sup> [http://www.greenemotion-project.eu/upload/pdf/deliverables/D7\\_2-Standardization-issues-and-needs.pdf](http://www.greenemotion-project.eu/upload/pdf/deliverables/D7_2-Standardization-issues-and-needs.pdf)

<sup>9</sup> In case of a 3-phase power line



### 2.1.3 The identification and billing system

This is the system that identifies the driver (or the car) and subsequently communicates with the network's back office to secure payment or at least to check whether the driver is known to the central system. In other words, this system provides the link between the driver and the network operator and/or service provider. Standardization of these systems, or compatibility between them, is crucial to realizing interoperability or roaming between the different recharging networks, both for national as well as international interoperability. Interoperability between networks also requires a higher level system (a clearing house) that connects the back-offices of individual networks and that takes care of financial transactions between the network operators (or service providers). This report will not go into the technical details of these systems, but there are several options for identification of the driver and to communicate with the back-office(s). The most popular identification method today is the use of smart Radio-frequency identification (**RFID**) cards. Identification by means of a mobile phone or direct communication between the car and the charger are also in use or under development. All of these options can be used in subscription based systems in which the system 'knows' the driver and can allow the driver to charge the EV. The driver is then also billed for the charging time or energy use (when the membership does not include energy use on a flat rate basis). In case of roaming between networks, the system should be able to acquire information about the user from its own network and send a bill to that network. Mobile phone identification can also be used for ad hoc charging by means of an **SMS** payment and this option therefore provides, theoretically at least, most flexibility.

### 3. A History of Electric Vehicle Recharging Plugs

In the following we briefly describe how the various plug types came about and how standardization bodies and industry organizations from the power and automotive industry have tried to steer these developments.

#### 3.1 AC Charging

The first electric vehicle projects in the 2000s in which the new generation of vehicles were used and for which recharging infrastructures were built, were projects in which car manufacturers and local utilities cooperated to develop and test their vehicles and charging equipment. Often, a local government took part in the project as well and, in case the utility did not produce its own chargers, a dedicated charging equipment developer was also involved. Such local networks emerged mostly in Europe, Japan, and California and they typically showed vertical integration in networks of different stakeholders in the emerging value chain. For instance, a project in London brought together EDF Energy (the British branch of Electricité de France), Smart (Daimler), the charging equipment developer Elektromotive, and the local transport agency Transport for London. The structure of these local networks would by themselves not allow the exchange of knowledge, let alone standardization, between multiple car manufacturers or multiple utilities. However, the number of projects continued to increase and eventually many actors were involved in multiple projects and they were able, in theory at least, to exchange knowledge between the different local projects they were involved in. Next to the increasing numbers of cross-linkages between these vertically organized local networks, a number of horizontally orientated initiatives provided platforms for broader knowledge exchange and ultimately for actual standardization activities.

In terms of formal standardization activities, the pinnacle of horizontal cooperation in this respect, the International Electrotechnical Commission (IEC) has been the most important actor with regard to electrotechnical standards. Several IEC-workgroups have been established in which automakers, charging equipment developers, and electric utilities were involved. In 2009, the IEC released a set of criteria with which a common EV standard plug design had to comply.<sup>10</sup> According to these criteria, a plug had to:

- be rated for all regular AC voltages and currents in use worldwide
- be compatible with single and 3-phase electric grid
- be compatible with specific communication protocols
- be low-priced, durable and safe to use
- be lockable to prevent theft and tampering
- be able to withstand a range of weather conditions.<sup>11</sup>

As a result of the IEC's efforts, a standard document was released in 2011 (replacing an earlier 2003 edition). The first part of this IEC 62196 standard specifies a number of technical and safety requirements of the plug and socket and the second part lists three specific physical

---

<sup>10</sup> IEC Trying To Standardize EV and Plug-in Charging Cables, 2009, Green Car Reports, [http://www.greencarreports.com/news/1021843\\_iec-trying-to-standardize-ev-and-plug-in-charging-cables](http://www.greencarreports.com/news/1021843_iec-trying-to-standardize-ev-and-plug-in-charging-cables)

<sup>11</sup> IEC Working to Establish Standards for Smart Charging Grid. 2009, Green Car Reports, [http://www.greencarreports.com/news/1021842\\_iec-working-to-establish-standards-for-smart-charging-grid](http://www.greencarreports.com/news/1021842_iec-working-to-establish-standards-for-smart-charging-grid) Last accessed 14 May 2013

designs (formally referred to as Types 1, 2, and 3 by the IEC) that had emerged by that time.<sup>12</sup> In the following we describe their emergence, their mutual competition, and the attempts of other organizations to define standards.

### 3.1.1 Type 1: the Yazaki plug

In the United States, the Society for Automotive Engineers (SAE) had taken the initiative to develop a new plug standard. This standard was to replace a standard from the 1990s that was only suitable for lower power levels while the new generation of EVs would require higher levels for faster charging. An SAE task force was set up in 2006 to define a standard for such a plug and its safety requirements. Led by General Motors (GM), several companies participated in the process: GM, Chrysler, Ford, Toyota, Honda, Nissan and Tesla Motors, a start-up firm dedicated to the development of EVs. After the requirements were defined by the task force, in terms of performance and safety requirements, the Japanese manufacturer of power network equipment Yazaki was asked to design and develop the actual plug. In 2009 the resulting plug was tested and certified by Underwriters Laboratory (one of the U.S. certification companies) and it was finally approved by the SAE in January 2010<sup>13</sup> as the new SAE J1772 standard plug. The plug enables charging at 120 or 220 Volt and it has two additional pins, next to two power pins and one ground pin, for safety and communication features. Because of its manufacturer, this plug is often referred to as the Yazaki plug. It was developed with the help of European and Japanese experts and car manufacturers and therefore it was expected to be suitable for those markets as well. Jack Pokrzywa, Manager of Ground Vehicle Standards for the SAE claimed that ‘the SAE standard represents a big step forward in the move toward electrification of the vehicle on a global scale’.<sup>14</sup> However, he also noted that ‘given the differences in electrical architectures among some countries, it is too soon to say how widely J1772 will be adopted outside the U.S.’<sup>15</sup>. Because of the similarities in grid architectures between the U.S. and Japan the Yazaki plug was embraced there as well. The Yazaki plug is exclusively used as a vehicle-side plug and it needs a corresponding inlet on the vehicle. It is designed primarily for use at charging stations with cables that are permanently fixed to the charging station. It is also possible for drivers to carry their own loose cables with a Yazaki plug on the vehicle end and another (i.e. a standard mains plug) on the wall end of the cable.

### 3.1.2 Type 2: the Mennekes plug

In Europe, the specifications of the Yazaki plug were deemed insufficient as the European electricity grid typically is more powerful and would allow faster recharging as compared to the U.S. and Japan. The main difference is in the availability of so-called three-phase power at virtually all connections, including households. The idea of having fixed cables in public space was also rejected out of fear for theft and vandalism. A European plug had to be designed for these power levels and it had to be a plug that could be used on both the car side as well as on the infrastructure side. Leading automakers Daimler, BMW, Volkswagen, Fiat, Ford, GM, Toyota, and Mitsubishi, together with electricity companies RWE, Vattenfall, EDF, E.on, Npower, Endesa, and Enel reached an agreement on a standard plug for electric

<sup>12</sup> A step forward for global EV roll-out, 2011, IEC website, <http://www.iec.ch/newslog/2011/nr0411.htm>, last accessed 14 May 2013

<sup>13</sup> SAE standard on EV charging connector approved, 2010, SAE website, <http://www.sae.org/mags/AEI/7479>, last accessed 14 May 2013

<sup>14</sup> SAE standard on EV charging connector approved, 2010, SAE website, <http://www.sae.org/mags/AEI/7479>, last accessed 14 May 2013

<sup>15</sup> SAE standard on EV charging connector approved, 2010, SAE website, <http://www.sae.org/mags/AEI/7479>, last accessed 14 May 2013

vehicles in 2009.<sup>16</sup> This plug was developed by Mennekes Elektrotechnik, the German manufacturer of industrial plugs, sockets and connectors. It was first used in two pilot projects in Germany in which respectively Vattenfall and BMW and RWE and Smart had cooperated in 2008.<sup>17</sup>

This plug became known as the ‘Mennekes plug’, but formally it is referred to as the Type 2 plug according to the IEC nomenclature. As this plug was physically not compatible with the U.S. Type 1 (Yazaki) plug, some concern was uttered over the lack of global standardization and compatibility. For instance, BMW, Daimler and Volkswagen uttered their concerns at a Californian Air Resources Board Technology Symposium in September 2009.<sup>18</sup> They called for global standardization of the charging infrastructure. The car manufacturers proposed to harmonize the (AC) charging standards, because they felt this was necessary for electric vehicles to become mainstream. Despite these calls, the Association of German Carmakers (VDA) agreed in 2010 that the Type 2 was their preferred plug.<sup>19</sup> Amongst its members are Volkswagen, Daimler, BMW, Opel and the German division of Ford and Fiat. The association selected the Type 2 plug, because it was the only plug available that complied with their criteria.

### 3.1.3 Type 3: the Scame plug

The selection of the Mennekes plug by this large group of car manufacturers made it seem as if a European standard was reached. However, a group of French and Italian electrical equipment manufacturers organized themselves in the EV Plug Alliance and rejected the Mennekes design and proposed their own plug. This alternative plug was originally designed by the Italian plug manufacturer Scame. Notably, the developer of the Type 1 plug, Yazaki, also joined the EV Plug Alliance. The official reason for rejecting the Mennekes plug was an electrotechnical safety requirement that prescribed so-called shutters in outdoor sockets. These shutters were to prevent children from manoeuvring their fingers in the sockets. The Mennekes design did not include such shutters and another plug and socket combination was thus needed, according to these companies. The eventual alternative plug with shutters was developed by the French company Schneider. Despite the legal basis for the development of this alternative plug, it is widely believed that industrial interests also played a role.<sup>20</sup> The assumed interests are the prestige that comes with designing the winning plug and direct benefits to be reaped.

### 3.1.4 The role of standardization bodies and industry consortia

The functional and safety requirements of EV plugs and sockets are defined by the IEC in the first part of the before mentioned IEC62196 standard. The second part of this standard describes all three designs that were described above and no further choices are prescribed. The European counterpart of the IEC, the CENELEC, was asked by the European

<sup>16</sup> European Wide Standardised Plugs for Electric Vehicles, 2009, Cars21. <http://www.cars21.com/news/view/53>, Last accessed 14 May 2014

<sup>17</sup> The European standard charging plug for cars is selected after Mennekes design, 2009, Green Autoblog, <http://green.autoblog.com/2009/05/20/the-european-standard-charging-plug-for-cars-is-selected-after-m/>, Last accessed 14 May 2013

<sup>18</sup> E-Mobility Infrastructure Standardization, 2009, R. Oestreiche, W. Preuschoff (Daimler AG) R. Bogenberger (BMW AG) presentation during CARB ZEV Technology Symposium Sacramento, CA, [http://www.arb.ca.gov/msprog/zevprog/2009symposium/presentations/preuschoff\\_oestreicher.pdf](http://www.arb.ca.gov/msprog/zevprog/2009symposium/presentations/preuschoff_oestreicher.pdf), Last accessed 14 May 2013

<sup>19</sup> France and Germany standardise plugs, 2010, Cars21, <http://www.cars21.com/news/view/238>, Last accessed 14 May 2013

<sup>20</sup> Electric car makers fight over plug standard, 2011, Euractiv website, <http://www.euractiv.com/enterprise-jobs/electric-car-makers-fight-plug-standard-news-503854>, Last accessed 14 May 2013

Commission, in 2011, to define a specific design as the EU standard, but this has not resulted in such a decision yet.<sup>21</sup> On the automotive side, decisions on standardization had taken less time. As said, the US based SAE had decided that the Yazaki plug was to be the US standard and this has been widely adopted in various local settings. The German VDA attempted the same in Europe with the Mennekes plug, which did not reach the same status as the Yazaki plug in the US and Japan. While the association of European car manufacturers (ACEA) sided with the Mennekes consortium and provided arguments why the Schneider plug with shutters was not really needed,<sup>22</sup> the European electricity sector did not want to choose between the two competing designs.<sup>23</sup> Interestingly, the decisiveness of the car manufacturers only related to the infrastructure. The ACEA claimed, for instance, that standardization was crucial to the success of EVs, but argued that this had to take place on the infrastructure-side and not so much on the car-side. In cars, multiple inlet designs were already in use by different car makers and standardization were supposedly no longer a realistic option.<sup>24</sup> It thus recommended the Type 2 socket (Mennekes) as the European standard for public charging infrastructures and vowed that manufacturers would provide matching cables with their cars. The European electricity sector, as united in the EURELECTRIC, recommended that the standards set by the IEC were to be followed, without specifying a design.<sup>25</sup> Presumably this has to do with the fact that its members had already installed quite some infrastructure with different sockets (local level lock-in) and that no agreement was reached between its German and French and Italian European members.

In May 2012, the ACEA and EURELECTRIC (together with CLEPA, representing automotive suppliers) released a joint statement to call upon the European Commission to finally define a European plug standard.<sup>26</sup> However, according to the accompanying individual statements, the two industries still could not agree on the specific design of such a standard. The ACEA continued to promote the Type 2 Mennekes plug for the infrastructure side and it now even recommended its members to use it as a vehicle inlet as well (possibly as part of the so-called Combo inlet design which will be discussed in the following section).<sup>27</sup> The EURELECTRIC however still refrained from choosing between the German and French/Italian design.<sup>28</sup>

### 3.2 DC Charging

The DC charging trajectory emerged later than the AC trajectory; the two trajectories have distinct standardization dynamics. The AC trajectory started with many local projects after which standardization efforts followed. The DC trajectory in contrast started with the definition of a standard. Only later projects started, around the world, in which the plugs were

<sup>21</sup> CENELEC, Standardization for road vehicles and associated infrastructure - Report in response to Commission Mandate M/468 concerning the charging of electric vehicles, in: F.G.o.E. Electro-Mobility (Ed.), CENELEC, Brussels, 2011

<sup>22</sup> ACEA, ACEA position on the Standardization of the Charging of Electrically Chargeable Vehicles., in: European Automobile Manufacturers' Association ACEA (Ed.), Brussels, 2010

<sup>23</sup> EURELECTRIC, Standardisation of Electric Vehicle Charging Infrastructure - Declaration by the European Electricity Industry, in: Union of the Electricity Industry-EURELECTRIC (Ed.), Brussels, 2009.

<sup>24</sup> ACEA, ACEA position on the Standardization of the Charging of Electrically Chargeable Vehicles., in: European Automobile Manufacturers' Association ACEA (Ed.), Brussels, 2010

<sup>25</sup> EURELECTRIC, Standardisation of Electric Vehicle Charging Infrastructure - Declaration by the European Electricity Industry, in: Union of the Electricity Industry-EURELECTRIC (Ed.), Brussels, 2009

<sup>26</sup> ACEA, CLEPA, EURELECTRIC, ACEA, CLEPA and EURELECTRIC promote single standard for charging electrically-chargeable vehicles, in: C.a.E. ACEA (Ed.), Brussels, 2012

<sup>27</sup> ACEA, ACEA position and recommendations for the standardization of the charging of electrically chargeable vehicles, in: European Automobile Manufacturers' Association ACEA (Ed.), Brussels, 2012

<sup>28</sup> EURELECTRIC, Facilitating e-mobility: EURELECTRIC views on charging infrastructure, in: Union of the Electricity Industry-EURELECTRIC (Ed.), Brussels, 2012

actually used. This standard definition was later challenged by a large consortium of firms with their own standard. In contrast to the AC trajectory, for which standardization was sought on a continental scale, the DC trajectory is characterized by a struggle for global standardization.

### 3.2.1 CHAdeMO

The development of DC fast charging systems was initiated by the Japanese power company TEPCO as early as 2007. Their power grid, like that of the U.S. allows only charging at 110 Volt at most connections, and charging typically takes a lot of time (10-12 hrs). Because improvement of the grid in general towards 220 Volt or three-phase power was no option, the Japanese took an interest in DC fast charging at a limited number of locations. By doing so, the Japanese thus decided to leapfrog the three-phase AC solution that was being developed in Europe. To define a standard for DC charging, TEPCO set up the CHAdeMO association (Charge de Move) in 2010. Its members were both from the Japanese car industry (Mitsubishi, Nissan, Subaru, and Toyota) as well as a number of electric utilities. On the basis of their specifications, the 'Japan Automotive Research Institute' subsequently designed a plug that is designed for high voltages and high direct current levels. The CHAdeMO standard prescribes the use of a fixed cable and plug on the infrastructure side. Using loose cables for DC charging is considered unsafe and the cost and weight of the cables (because of their high power rating) make that carrying the cables would be too much a burden to drivers. This does mean however that a CHAdeMO charging station can only be used for cars with a matching CHAdeMO inlet and that it is not possible to use alternative cables such as for AC charging. The Japanese car makers took part in the CHAdeMO association and they have subsequently equipped their cars with a CHAdeMO inlet (i.e. the Nissan Leaf and the Mitsubishi iMiev). No other manufacturers have adopted the CHAdeMO or any other DC charging standard. Still, even though it was originally a Japanese standard, the fact that the Japanese EVs were globally marketed meant that the CHAdeMO standard had to be used at American and European fast-charging stations as well and that it became the de-facto global standard for DC fast charging. The plug design is however not (yet) recognized as such by the IEC even though its power and safety ratings comply with the IEC 62196 norms.

A major drawback of the CHAdeMO standard is that it prescribes a separate vehicle inlet that is used for DC charging exclusively. Another AC vehicle inlet is thus always necessary next to it. American and European car manufacturers have therefore refused to adopt CHAdeMO and proposed an alternative plug that combined AC and DC charging in one vehicle inlet.<sup>29</sup>

### 3.2.2 The Combo plug

Five German car manufacturers (Audi, BMW, Daimler, Porsche, and Volkswagen) were the first to propose the development of a combined AC and DC plug. They were later joined by GM and Ford. The Combo plug, as it was called, was formally announced in 2012 at the Electric Vehicle Symposium in Los Angeles. There are two versions of the plug. The U.S. version combines the Type 1 Yazaki AC design with the additional DC pins and the European version combines the DC pins with the Type 2 Mennekes AC design. The European version therefore also allows three-phase power AC charging. Like the CHAdeMO plug, the standard prescribes fixed cables, implying that a match is always necessary between the car and the charging equipment.

---

<sup>29</sup> SAE poised to reject Japan's fast-charge choice, 2012, Autonews, <http://www.autonews.com/apps/pbcs.dll/article?AID=/20120312/OEM06/303129990>, Last accessed 14 May 2013

So far, no cars have been outfitted with the new combo inlet and no matching charging stations have been installed. But, if the European and U.S. car makers push through with their design, it is in fact likely that future DC fast charging stations will have two separate cables for CHAdeMO and Combo compatible cars.

## 4. Plugs in use in the NSR region

Despite the fact that many countries in the north of Europe have adopted the Type 2 plug as their local standard and that the EU has underscored this choice with its 2012 Directive, different plugs and sockets are still in use as well and roaming between different networks is by and far still impossible. Below we briefly describe the current situation in the seven NSR countries and we highlight initiatives that specifically aim to realize true interoperability.

### 4.1 United Kingdom

In the UK, the vast majority of the recharging points have been realized as part of the Plugged-in-Places initiative. These PiP's have been set up in eight different regions and in each of the regions, separate systems have been developed and roaming is by and large impossible. The problem is not so much with the sockets on the chargers. Many chargers in the UK offer both a regular British three-pin socket (BS 1363) and a Type 2 socket. This is not always the case however and drivers still need to carry two cables with them to make sure they can charge at any charging station. In an attempt to reduce the variety in sockets, national government decided that from April 2012 onwards, all chargers that are (partly) funded with public money have to offer at least a Type 2 socket. Insofar as DC fast chargers are installed, these are all CHAdeMO (among others at Nissan dealerships).

The real issue with interoperability in the UK, as in many other countries, is that the different PiP networks use different identification and billing systems and that roaming is virtually impossible between these networks. One exception is the interoperability between the networks in London and East of England (north of London) where EV drivers can use their identification cards on both networks. The real problem is much more in the different identification systems that are used to grant access to chargers and to arrange payment. As said, various identification and billing protocols are in use in the individual PiP's, but there is an on-going initiative to harmonize these and to use the Open Charge Point Protocol OCPP protocol to realize this ambition. It is also noteworthy that in the U.K. there is a trend to move away from flat-rate subscription based systems to pay-per-charge systems in which drivers either pay with their debit or credit card that is connected to their RFID charging card or by paying with their mobile phone. This move can be interpreted as a step towards commercialization of EV recharging and the development of viable business models.

Four major networks have emerged in recent years. In London there's the Source London network that offers a variety of 3-pin sockets, Type 1 plugs and Type 2 sockets.<sup>30</sup> There is one CHAdeMO fast charger in the city centre. These chargers can be used in combination with a Source London membership card (RFID) that costs 10 pounds per year.

The Charge Your Car network is based primarily in the North East and started off as the regional PiP. This network consists of many local hosts that own the actual stations. CYC provides interoperability and roaming by providing a RFID card that works on all connected stations. Local hosts can either offer free electricity or can charge the EV driver via the RFID card and the driver's debit or credit card. The network includes both AC and DC CHAdeMO chargers. The AC chargers differ in terms of the sockets (British 3-pin, Type 2). Some fast-charge stations offer both CHAdeMO (50kW) and AC Type 2 (22kW).<sup>31</sup>

The POLAR network offers a subscription based RFID card that can be used for POLAR's own network and in the future also for the Source London network. POLAR's chargers are mainly found at strategic locations between the already existing PiP networks. In addition,

---

30 <https://www.sourcelondon.net/map.php>

31 <http://chargeyourcar.org.uk/#map>



POLAR will also install several DC fast chargers throughout the country.<sup>32</sup> Semi-fast AC Type 2 chargers are offered nationwide by ECOTRICITY<sup>33</sup> in collaboration with and located at Welcome Break service stations. These will be complemented with CHAdeMO fast chargers in the future.

## 4.2 Belgium

In Belgium, the vast majority of EV chargers have been installed in pilot projects of the Flemish Living Lab initiative. These projects were explicitly meant to develop new technologies and systems and to learn about their usage. Technological variety was therefore fostered and standardization was never a priority. Agreements have been made however to use Type 2 sockets (possibly in combination with other sockets) and RFID cards for identification. Talks are on-going to realize interoperability among the pilot projects and the networks of several commercial operators. These include the networks of Blue Corner, The Plug-in Company and The New Motion from the Netherlands that also operates several chargers in Flanders.<sup>34</sup> BlueCorner is Belgium's biggest operator with a network of 50 charging stations which are produced by the company itself (under the Enovates brand). This is a subscription based network and its members use an RFID card to access the chargers, but they do pay for the electricity on a time-basis. BlueCorner's chargers offer a Type 2 and CEE 7/5 (French standard) socket. The Plug-in Company<sup>35</sup> offers 16 stations<sup>36</sup> with Type 1 and Type 2 connections and these are found among others at IKEA stores. The Plug-in Company uses an SMS payment system for its chargers in public space.

In terms of international interoperability, Blue Corner and The New Motion have both embraced the e-clearing.net initiative to enable interoperability with the Dutch and parts of the German network<sup>37</sup> (stations that are part of the Ladenetz initiative). Interestingly, Blue Corner has also signed an agreement with Hsubject, the German commercial initiative to realize interoperability and payment services.<sup>38</sup>

## 4.3 The Netherlands

Of the roughly 2500 charging stations in the Netherlands, about 2000 have been installed by the E-Laad foundation. E-Laad was founded by (almost all of) the grid operators and offered free chargers to municipalities.<sup>39</sup> Other chargers were installed by a number of large cities (e.g. Amsterdam, Rotterdam, and Utrecht) and some as part of individual pilot projects. All of the E-Laad stations and the vast majority of municipal stations are fitted with Type 2 sockets. In fact, it was decided early on by a broad range of stakeholders that this was to be the Dutch standard for EV plugs and socket. Only some older charging stations still make use of the standard three phase power socket (IEC 60309 industrial plug). These are for instance part of an early network that was installed in the city of Amsterdam.

Today, several companies (among others The New Motion) offer RFID cards that allow usage of all E-Laad chargers and the networks that were commissioned by several municipalities (e.g. Amsterdam, Rotterdam, and Utrecht). These cards are offered for free, but EV-drivers pay for the electricity on a charging-time basis.

<sup>32</sup> <http://www.polarnetwork.com/>

<sup>33</sup> <http://www.ecotricity.co.uk/for-the-road>

<sup>34</sup> [www.bluecorner.be](http://www.bluecorner.be)

<sup>35</sup> <http://www.theplugincompany.com/en/>

<sup>36</sup> These are for electric vehicles (according to [www.openchargemap.org](http://www.openchargemap.org)), the network further consists of hundreds of chargers for e-bikes.

<sup>37</sup> <http://www.e-clearing.net/news.php>

<sup>38</sup> [http://www.hsubject.com/pdf/PM\\_hsubject\\_20130522\\_EN.pdf](http://www.hsubject.com/pdf/PM_hsubject_20130522_EN.pdf)

<sup>39</sup> <http://www.e-laad.nl/>

There are about 50 DC fast chargers in the Netherlands, all of which use the CHAdeMO protocol and plug. These are all paid for on a pay-per-charge (time) basis using a specific RFID card of the fast-charger operator. The E-Laad network developed the OCCP (open charging point protocol) for communication between individual charging stations and the network's central system<sup>40</sup> that is now in use in several countries. And it is also involved in the development of the OCHP (open clearing house protocol) for communication between multiple networks to allow roaming of customers and billing across networks. The OCHP forms the basis for the international roaming initiative e-clearing.net.

#### 4.4 Germany

The German situation is comparable to the U.K. and Belgium. As a result of regionally oriented test and demonstration projects, separate charging networks with different designs have emerged. In Germany, in contrast to the U.K. and Belgium, the plug itself was early on standardized and the Type 2 plug (a German design) was selected. Roaming between the different networks is however not possible due to differences in the identification and billing systems. Besides local charging networks that have installed as part of the model regions (Modellregionen) initiatives, charging stations have been installed by the large energy companies such as Vattenfall (mainly in Hamburg and Berlin) and RWE (throughout the country, but mostly in North Rhine-Westphalia). The RFID passes of both of these private networks are not interchangeable and in a city like Berlin, roaming between the separate networks is not possible. There are currently no plans to realize interoperability between them and, even more so, RWE is co-founder of the joint-venture Hubeject<sup>41</sup> (together with the BMW Group, Bosch, Daimler, EnBW, and Siemens), while Vattenfall has joined the Ladenetz.de initiative<sup>42</sup> (a cooperation of 21 municipal utilities and several international stakeholders). Fast chargers have been installed on only a few locations in Germany and these are all CHAdeMO chargers. New fast chargers are likely to feature the new COMBO 2 plug to fit with the vehicles that have been announced by German car manufacturers for the coming years.

#### 4.5 Denmark

The Danish recharging infrastructure consists of multiple networks that were set up by private companies, utilities, and local governments. Today there is agreement that all chargers should be equipped with Type 2 sockets, but in practice many chargers only offer Schuko or CEE industrial sockets.<sup>43</sup> The most prominent network operator in Denmark is CLEVER which operates both regular as well as DC quick chargers in public space. Its members make use of an RFID card with which they can charge on a pay per kWh basis. Until its bankruptcy, Better Place was the other major operator in Denmark with both its swapping stations as well as hundreds of regular chargers (Type 2). Other EV drivers were able to use the network on an ad hoc basis after a phone call to Better Place's service centre. The charger was then opened remotely and electricity was paid for by credit card.

As the core of the business model of the individual operators is mostly with home charging services, realizing interoperability is not too high on their agendas. However, a Clean Charge Solutions, one of the smaller operators with only a couple of chargers in public space, is

40 [http://www.ocppforum.net/sites/default/files/ocpp%201%205%20-%20a%20functional%20description%20v2%200\\_0.pdf](http://www.ocppforum.net/sites/default/files/ocpp%201%205%20-%20a%20functional%20description%20v2%200_0.pdf)

41 [https://www.press.bmwgroup.com/pressclub/p/pgl/pressDetail.html?title=hubeject-aims-at-connecting-public-charging-infrastructure-for-electric-vehicles-across-european&outputChannelId=6&id=T0134530EN&left\\_menu\\_item=node\\_\\_2379](https://www.press.bmwgroup.com/pressclub/p/pgl/pressDetail.html?title=hubeject-aims-at-connecting-public-charging-infrastructure-for-electric-vehicles-across-european&outputChannelId=6&id=T0134530EN&left_menu_item=node__2379)

42 <http://www.pressebox.de/pressemitteilung/vattenfall-gmbh/Kooperation-fuer-barrierefreie-Elektromobilitaet/boxid/571560>

43 <http://www.uppladdning.nu/>

linking up with the German Hsubject initiative to realize international interoperability and also to connect with Hsubject mobile phone based payment system.

#### 4.6 Sweden

Sweden is one of the countries where the recharging infrastructure emerges relatively slowly, possibly due to the fact that the Swedish national government is still defining its position in relation to electric mobility. The resulting lack of direction and coordination between the various initiatives has probably also caused the wide variety of plug and socket types that are in use. Sweden is one of the few countries in Europe where Type 1 plugs are in use<sup>44</sup> (often next to Type 2 sockets) and continued installation of Type 1 plugs (on fixed cables) is being considered despite the likelihood of Type 2 becoming a European standard. This is especially the case in the Jämtland region (in the centre of Sweden) where the local utility Jämtkraft has installed a small network of chargers. In the city of Gothenburg, most chargers still offer Schuko sockets.

Identification and billing is not an issue in Sweden and chargers in public space are by and large not equipped for this. Since most electricity in Sweden is generated by hydropower and nuclear power plants, electricity is relatively cheap and elaborate billing systems are therefore not worthwhile. In Gothenburg for instance, the price of electricity is simply part of the regular parking tariffs (and for long-term parking the parking tariffs are a bit higher for EVs). In addition to the ‘real’ EV chargers, there are hundreds of thousands of engine pre-heater sockets in Sweden that can be used to charge an EV. In some instances these have been upgraded with additional safety features to make EV charging safer from these sockets.<sup>45</sup>

#### 4.7 Norway

Norway is one of the countries with the highest number of charging stations in Europe. Many of these are basic Schuko sockets (CEE 7/4) that are installed in public space. Only the newest chargers are equipped with Type 2 sockets, for instance in the city of Oslo, but always next to a Schuko socket. A key is needed to access the chargers and the chargers are free to use for members of the Norwegian EV Association. Similar to Sweden, power in Norway is predominantly generated at hydropower plants and billing of the electricity is thus not a priority and identification and billing systems are not an issue.

Norway also has quite a number of DC fast chargers that make use of the CHAdeMO protocol and plugs. These can be used in combination with an RFID card. The several network operators, all connected to regional energy companies, do allow roaming between the networks, but this is done on an ad hoc basis. This means that an EV driver needs to call the network operator and is subsequently granted (one-time or permanent) access (‘added to the white list’) to the network. So far, no billing takes place as the number of EV drivers is still fairly limited and any billing system would be more expensive than the actual charging costs. Also, it is thought that roaming is spread evenly among the operators, so there is no direct need to settle costs among the operators.

---

44 <http://www.uppladdning.nu/>

45 Elforsk, Laddningsinfrastruktur – Marknadsinventering och rekommendationer, Lennart Spante och ”Arbetsgrupp P5” Juni 2010

## 5. Initiatives to realize international interoperability

### 5.1 Ladenetz

Ladenetz originated from the cooperation between the local utilities (Stadtwerke) of Aachen, Duisburg, and Osnabruck and a further 18 utilities have joined them later on.<sup>46</sup> The focus of the initiative is to enable roaming between the charging networks of the individual utilities and in practice this means that drivers are able to charge off any charger with a single RFID card. The protocol do so is the so-called Open Clearing House Protocol (OCHP) with which the individual networks communicate with each other to exchange user data and to take care of the financial transactions. Having started as a national platform of semi-public organizations, Ladenetz is now expanding the use of the protocol and was joined by Vattenfall for instance. Internationally, Ladenetz has initiated the e-clearing.net platform on which the OCHP is used to enable cross border roaming.<sup>47</sup> In March 2012 the so-called ‘Treaty of Vaals’ was signed<sup>48</sup> to confirm this international cooperation and the treaty was signed by Ladenetz.de, the E-Laad foundation from the Netherlands, BlueCorner and Becharged from Belgium, Estonteco from Luxemburg, Vlotte from Austria, ESBeCars from Ireland, and Inteli from Portugal. All these network operators will use the OCHP for both national as well as international roaming. In an earlier stage The New Motion, the largest service provider of the Netherlands, was one of the first to join the e-clearing.net initiative. The entire Dutch network is therefore open to drivers from abroad using an e-clearing.net compatible RFID card.

### 5.2 Hsubject

Whereas Ladenetz and e-clearing.net are not-for-profit attempts to realize interoperability, Ladenetz’ spin-off Hsubject tries to do the same on a commercial basis. Hsubject is a joint venture of BMW, Bosch, Daimler, EnBW (the regional utility of Baden-Württemberg), RWE, and Siemens.<sup>49</sup> It develops the so-called eRoaming platform that acts as a clearing house for network operators and service providers. Any network operator or service provider can join the platform and from there on allow customers of other associated operators to charge at its stations. Charging stations that are take part in the Hsubject system feature a QR code that can be scanned by an app on the phone. The app then takes care of the identification of the driver and the subsequent financial transaction between the user’s own provider and the local host. Hsubject is quite similar to Ladenetz protocol, but the two systems are not directly compatible. It is however thinkable that both systems are used on top of each other and Ladenetz (or any other initiative of multiple network operators) could for instance be coupled to the Hsubject platform (‘hubbing the hubs’) True ad hoc roaming is however not possible since Hsubject only acts as a platform for other operators/service providers and not directly for customers.

### 5.3 Crome

One specifically interesting project is CROME (Cross-border Mobility for EVs). This is a German-French cooperation to enable cross border travel in the Alsace and Moselle regions in France and Baden-Württemberg region in Germany. Within this project, charging stations are

46 <http://ladenetz.de/index.php?id=partner>

47 <http://www.e-clearing.net/news.php>

48 [http://ladenetz.de/index.php?id=35&tx\\_ttnews%5Btt\\_news%5D=1070&cHash=277c3081cbe3b83b3b7f5017ea9d5ab7](http://ladenetz.de/index.php?id=35&tx_ttnews%5Btt_news%5D=1070&cHash=277c3081cbe3b83b3b7f5017ea9d5ab7)

49 [https://www.press.bmwgroup.com/pressclub/p/pcgl/pressDetail.html?title=hsubject-aims-at-connecting-public-charging-infrastructure-for-electric-vehicles-across-european&outputChannelId=6&id=T0134530EN&left\\_menu\\_item=node\\_\\_2379](https://www.press.bmwgroup.com/pressclub/p/pcgl/pressDetail.html?title=hsubject-aims-at-connecting-public-charging-infrastructure-for-electric-vehicles-across-european&outputChannelId=6&id=T0134530EN&left_menu_item=node__2379)

installed that can be used with a single RFID card on both sides of the border. Strikingly, these stations will offer both Type 2 and Type 3 sockets so that cross-border travellers do not have to carry along additional cables.<sup>50</sup>

#### 5.4 Green eMotion

Finally, the EU funded Green eMotion project also aims to develop standard for interoperability between charging networks. Green eMotion's standard is currently in the research and design phase and no implementation has taken place yet. Interestingly, many participants in the project are also active in the other initiatives and especially in the CROME project and Hubject (e.g. Siemens and Bosch).

---

<sup>50</sup> <http://crome-projekt.de/index.php?id=312>

## 6. Conclusions: looking forward

The development and acceptance of a European standard for recharging finds itself at an interesting intersection. Most countries are still struggling to define their national standard, especially for the identification and billing system, to enable their EV drivers to charge throughout the country. At the same, there are several initiatives to realize an interoperable European network. This could be the ideal point in time to push for international standardization, but from this report and the interviews that were conducted, it tentatively follows that the individual countries have prioritized their own standardization efforts over the international ones. In other words, those countries that have not realized domestic interoperability seem eager to do this on the short term. As a possible consequence, some of these national networks will create a barrier, resulting from a local lock-in, to international interoperability. As noted in relation to the individual countries, the plugs and sockets are not likely to be the real problem. Most countries are indeed moving towards the Type 2 plug as encouraged by the 2012 EU directive, sometimes in combination to locally popular plugs such as the Schuko or British 3-pin plug. In those instances where older infrastructure is still in use or where a local stakeholder does not subscribe to the emerging standard, EV drivers can still carry multiple plugs to solve the issue. One exception to this rule may be the mismatch between existing (or new) Type 1 chargers with a fixed cable (and attached Type 1 plug) and vehicles that will come onto the market in the coming years with a Type 2 vehicle inlet. These vehicles, that are often also capable of fast charging from a COMBO 2 charger, are quite likely to dominate the EU market for electric vehicles and network operators are therefore advised to at least offer another socket (next to the Type 1) cable on their chargers.

The real challenge however, as noted several times in the report, is with the identification and billing system. The Netherlands is the only country in which roaming is possible between the regular charging networks, in other countries like Norway and Sweden ‘roaming’ is possible because there’s no billing system at all. In other countries, there are at least two networks with their own identification and billing systems. In the case of DC fast charging, roaming is only possible on an ad hoc basis. The two major initiatives to realize international roaming, e-clearing.net and Hubeject, are incompatible and it is unlikely that they can exist side-by-side at individual charging stations or locations.

Given the unlikelihood of the emergence of a single European system for roaming between the networks, it would be best if charging station operators would be able to include ad hoc and payment systems in their chargers (using SMS or credit card payments for instance). This would be especially relevant for DC fast chargers to facilitate cross-border trips. Alternatively, in those countries where a national roaming system emerges, it would be convenient for foreign EV drivers to be able to purchase a (pre-paid) card with which they can charge from the local network(s) during their cross-border trip.

## About E-Mobility NSR

The Interreg North Sea Region project North Sea Electric Mobility Network (E-Mobility NSR) will help to create favorable conditions to promote the common development of e-mobility in the North Sea Region. Transnational support structures in the shape of a network and virtual routes are envisaged as part of the project, striving towards improving accessibility and the wider use of e-mobility in the North Sea Region countries.

[www.e-mobility-nsr.eu](http://www.e-mobility-nsr.eu)

## Contact Authors

Delft University of Technology, Faculty of Architecture and the Built Environment  
Sjoerd Bakker  
Jaffalaan 9  
P.O. Box 5030  
2600 GA Delft  
the Netherlands

+31(0)15-278 3005

[s.bakker-1@tudelft.nl](mailto:s.bakker-1@tudelft.nl)

## Contact Lead Partner:

Hamburg University of Applied Sciences  
Research and Transfer Centre “Applications of Life Sciences”  
Prof. Walter Leal  
Lohbrügger Kirchstraße 65  
21033 Hamburg  
Germany

+49-40-42875-6313

[e-mobility@ls.haw-hamburg.de](mailto:e-mobility@ls.haw-hamburg.de)